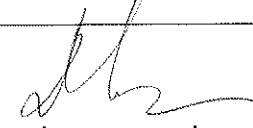

ΔΗΜΟΣ ΠΑΤΡΕΩΝ
ΔΙΕΥΘΥΝΣΗ ΑΡΧΙΤΕΚΤΟΝΙΚΟΥ ΕΡΓΟΥ- Η/Μ

ΜΕΤΑΤΡΟΠΗ ΕΓΚΑΣΤΑΣΕΩΝ Α.Σ.Ο. ΣΕ ΧΩΡΟ ΕΚΘΕΣΕΩΝ

ΑΡΧΙΤΕΚΤΟΝΙΚΗ	ΣΤΑΤΙΚΗ	Η/Μ ΜΕΛΕΤΕΣ
ΜΑΝΟΣ ΠΕΡΡΑΚΗΣ & ΣΥΝΕΡΓΑΤΕΣ Ε.Ε.	ΒΑΣΙΣ ΣΥΣΜ Α.Ε.	ΓΡ. & Μ. ΚΑΦΕΤΖΟΠΟΥΛΟΣ - Δ. ΜΠΕΝΑΚΗΣ & ΣΙΑ Ε.Ε.

ΕΠΙΚΑΙΡΟΠΟΙΗΣΗ ΜΕΛΕΤΗΣ

ΑΡΧΙΤΕΚΤΟΝΙΚΗΣ	ΣΤΑΤΙΚΗΣ	Η/Μ
ΔΕΡΒΙΣΟΠΟΥΛΟΥ ΕΛΕΝΗ-	ΝΙΚΟΛΑΟΥ ΔΗΜΗΤΡΗΣ-	ΔΑΡΣΙΝΟΣ ΒΑΣΙΛΕΙΟΣ
	 πολιτικός μηχανικός	

Ο ΠΡΟΪΣΤΑΜΕΝΟΣ
ΚΤΙΡΙΑΚΩΝ ΕΡΓΩΝ

Η Δ/ΝΤΡΙΑ
ΑΡΧΙΤΕΚΤΟΝΙΚΟΥ ΕΡΓΟΥ-Η/Μ

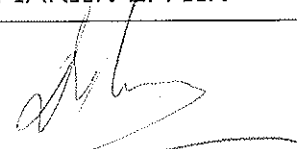
ΔΗΜΗΤΡΙΟΣ ΝΙΚΟΛΑΟΥ
πολιτικός μηχανικός

ΕΛΕΝΗ ΑΛΕΞΟΠΟΥΛΟΥ
αγρ. & τοπογράφος μηχανικός

ΤΕΥΧΟΣ: ΔΕΞΑΜΕΝΗ ΠΥΡΟΣΒΕΣΗΣ-
ΔΑΠΕΔΟ ΥΠΟΣΤΑΘΜΟΥ

ΑΡ. ΤΕΥΧΟΥΣ: ΣΤ-00

ΠΑΤΡΑ, ΙΟΥΝΙΟΣ 2017

ΘΕΩΡΗΘΗΚΕ

ΕΛΕΓΘΗΚΕ

ΔΗΜΟΣ ΠΑΤΡΕΩΝ
Δ/ΝΣΗ ΠΟΛΕΟΔΟΜΙΚΟΥ - ΚΥΚΛΟΦΟΡΙΑΚΟΥ
ΣΧΕΔΙΑΣΜΟΥ & ΔΟΜΗΣΗΣ
ΤΜΗΜΑ ΑΔΕΙΩΝ & ΕΛΕΓΧΟΥ ΔΟΜΗΣΗΣ
Θεωρείται μόνο ως προς την πληρότητα των
στοιχείων και όχι ως προς το περιεχόμενο.

Πάτρα 11 ΣΕΠ. 2017

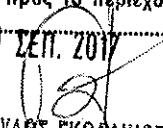
ΦΙΛΙΠΠΟΠΟΥΛΟΣ ΓΚΟΛΟΠΟΥΛΟΣ
Πολιτικός Μηχ/κός με Α' β

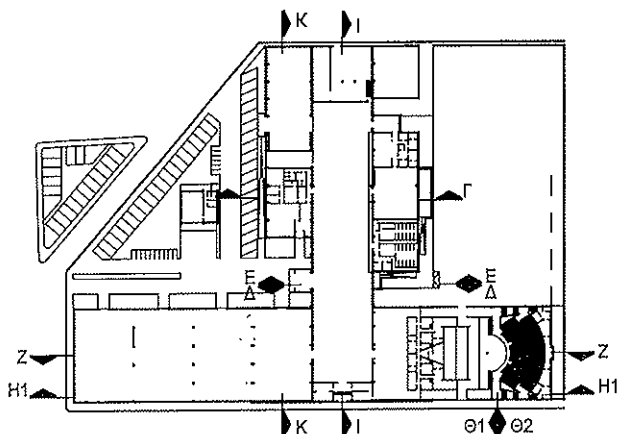

ΕΘΕΩΡΗΘΗ

Χωρίς έλεγχο των πράξεων
με ευθύνη του συντάξαντος
Μηχανικού.

Πάτρα 15-1-2006

**ΜΕΤΑΤΡΟΠΗ ΕΓΚΑΤΑΣΤΑΣΕΩΝ Α. Σ. Ο.
ΣΕ ΕΚΘΕΣΙΑΚΟ ΧΩΡΟ**

**ΦΙΛΙΠΠΟΠΟΥΛΟΣ ΓΚΟΛΦΙΝΟΣ
ΠΟΛΙΤΙΚΟΣ ΜΗΧΑΝΙΚΟΣ**

ΔΗΜΟΥ ΠΑΤΡΕΩΝ

ΔΗΜΟΣ ΠΑΤΡΕΩΝ - ΠΟΛΙΤΙΣΤΙΚΗ ΠΡΩΤΕΥΟΥΣΑ ΤΗΛ.: 966.268 - ΠΑΤΡΑ

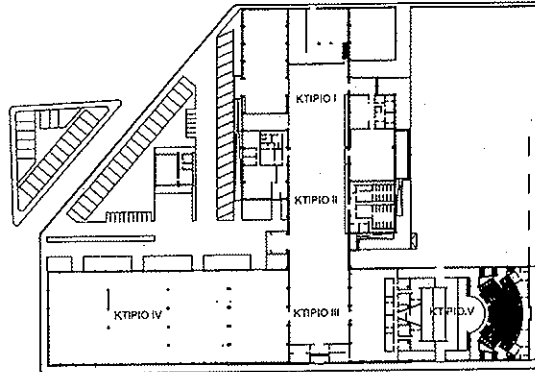

ΕΘΕΩΡΗΘΗ
Χωρίς έλεγχο των πράξεων κα
με ευθύνη του συντάξαντος
Μηχανικού.

ΠΑΤΡΑ 24-10-2006

Αντώνης Γκολφίνος
Πολιτικός Μηχανικός

**ΣΤΑΤΙΚΗ ΜΕΛΕΤΗ
ΣΤΑΔΙΟ ΕΦΑΡΜΟΓΗΣ**

ΔΕΞΑΜΕΝΗ ΠΥΡΟΣΒΕΣΗΣ ΑΡ. ΤΕΥΧΟΥΣ
ΔΑΠΕΔΟ ΥΠΟΣΤΑΘΜΟΥ **ΣΤ-00**

ΑΡΧΙΤΕΚΤΟΝΙΚΗ ΜΕΛΕΤΗ

ΜΑΝΟΣ ΠΕΡΡΑΚΗΣ ΚΑΙ ΣΥΝΕΡΓΑΤΕΣ Ε.Ε.

ΝΑΥΑΡΧΟΥ ΝΙΚΟΔΗΜΟΥ 2, 105 56, ΑΘΗΝΑ, ΤΗΛ.210 3218 901, ΦΑΞ 210 321 9 821 e_mail: m_perrakis@tee.gr

ΣΤΑΤΙΚΗ ΜΕΛΕΤΗ

ΒΑΣΙΣ ΣΥΣΜ ΑΕ ΣΤΑΤΙΚΕΣ, ΥΔΡΑΥΛΙΚΕΣ, ΣΥΓΚΟΙΝΩΝΙΑΚΕΣ ΜΕΛΕΤΕΣ

ΚΑΛΛΙΔΟΠΟΥΛΟΥ 6Β, 546 42 ΘΕΣΣΑΛΟΝΙΚΗ, ΤΗΛ.2310 865441 ΦΑΞ 2310 855828 e_mail xmylo@tee.gr

Η/ΜΗΧΑΝΟΛΟΓΙΚΗ ΜΕΛΕΤΗ

ΓΡ.& Μ. ΚΑΦΕΤΖΟΠΟΥΛΟΣ - Δ. ΜΠΕΝΑΚΗΣ & ΣΙΑ Ε.Ε.

ΔΟΥΚΙΣΣΗΣ ΠΛΑΚΕΝΤΙΑΣ 39, 152-34 ΧΑΛΑΝΔΡΙ, ΤΗΛ.210 683 9333,ΦΑΞ 210 683 9334 e_mail: k-m@k-m.gr

ΜΕΤΑΤΡΟΠΗ ΕΓΚΑΤΑΣΤΑΣΕΩΝ Α. Σ. Ο. ΣΕ ΕΚΘΕΣΙΑΚΟ ΧΩΡΟ

ΔΗΜΟΣ ΠΑΤΡΕΩΝ - ΠΟΛΙΤΙΣΤΙΚΗ ΠΡΩΤΕΥΟΥΣΑ

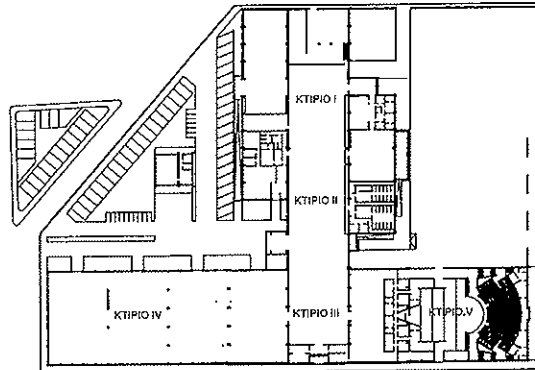

ΣΤΑΤΙΚΗ ΜΕΛΕΤΗ ΣΤΑΔΙΟ ΕΦΑΡΜΟΓΗΣ

ΔΕΞΑΜΕΝΗ ΠΥΡΟΣΒΕΣΗΣ ΑΡ. ΤΕΥΧΟΥΣ
ΔΑΠΕΔΟ ΥΠΟΣΤΑΘΜΟΥ ΣΤ-00

ΑΡΧΙΤΕΚΤΟΝΙΚΗ ΜΕΛΕΤΗ

ΜΑΝΟΣ ΠΕΡΡΑΚΗΣ ΚΑΙ ΣΥΝΕΡΓΑΤΕΣ Ε.Ε.

ΝΑΥΑΡΧΟΥ ΝΙΚΟΔΗΜΟΥ 2, 105 56, ΑΘΗΝΑ, ΤΗΛ.210 3218 901, ΦΑΞ 210 321 9 821 e_mail: m_perrakis@tee.gr

ΣΤΑΤΙΚΗ ΜΕΛΕΤΗ

ΒΑΣΙΣ ΣΥΣΜ ΑΕ ΣΤΑΤΙΚΕΣ, ΥΔΡΑΥΛΙΚΕΣ, ΣΥΓΚΟΙΝΩΝΙΑΚΕΣ ΜΕΛΕΤΕΣ

ΚΑΛΛΙΔΟΠΟΥΛΟΥ 6Β, 546 42 ΘΕΣΣΑΛΟΝΙΚΗ, ΤΗΛ.2310 865441 ΦΑΞ 2310 855828 e_mail xmylo@tee.gr

Η/ΜΗΧΑΝΟΛΟΓΙΚΗ ΜΕΛΕΤΗ

ΓΡ.& Μ. ΚΑΦΕΤΖΟΠΟΥΛΟΣ - Δ. ΜΠΕΝΑΚΗΣ & ΣΙΑ Ε.Ε.

ΔΟΥΚΙΣΣΗΣ ΠΛΑΚΕΝΤΙΑΣ 39, 152-34 ΧΑΛΑΝΔΡΙ, ΤΗΛ.210 683 9333,ΦΑΞ 210 683 9334 e_mail: k-m@k-m.gr

ΕΠΙΧΕΙΡΗΣΗ ΣΥΝΕΡΓΕΙΟ ΔΙΠΛ
ΣΤΑΤΙΚΕΣ ΥΔΡΑΥΛΙΚΕΣ/ΣΥΓΚΟΙΝΩΝΙΑΚΕΣ ΜΕΛΕΤΕΣ
ΚΑΛΛΙΔΟΠΟΥΛΟΥ 6Β 546 42 ΘΕΣΣΑΛΟΝΙΚΗ
ΤΗΛ. 842533 ΦΑΞ 950828
Α.Φ.Μ. 094371702 - Δ.Ο.Υ. ΦΑΞ ΘΕΣΣΑΛΟΝΙΚΗΣ

ΥΠΟΛΟΓΙΣΜΟΙ ΔΕΞΑΜΕΝΗΣ ΠΥΡΟΣΒΕΣΗΣ

ΣΤΑΤΙΚΗ ΕΠΙΛΥΣΗ ΔΕΞΑΜΕΝΗΣ

Scale 1 : 50.0
Structure - MODEL

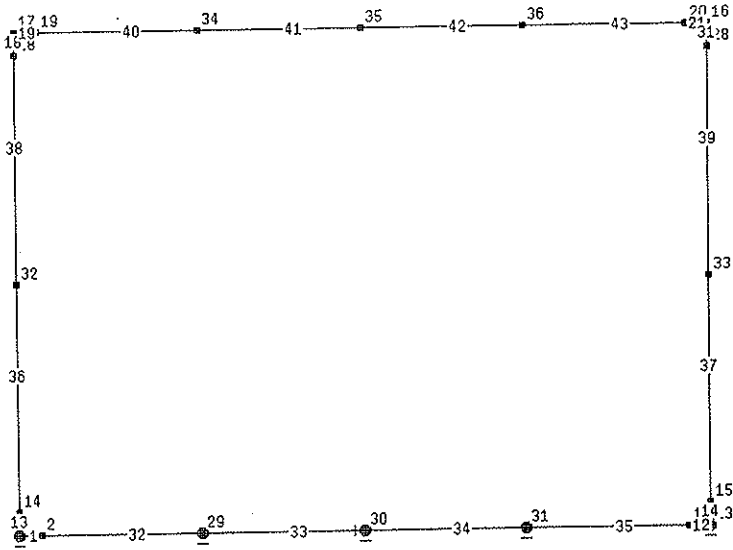

Scale 1 : 50.0
Structure

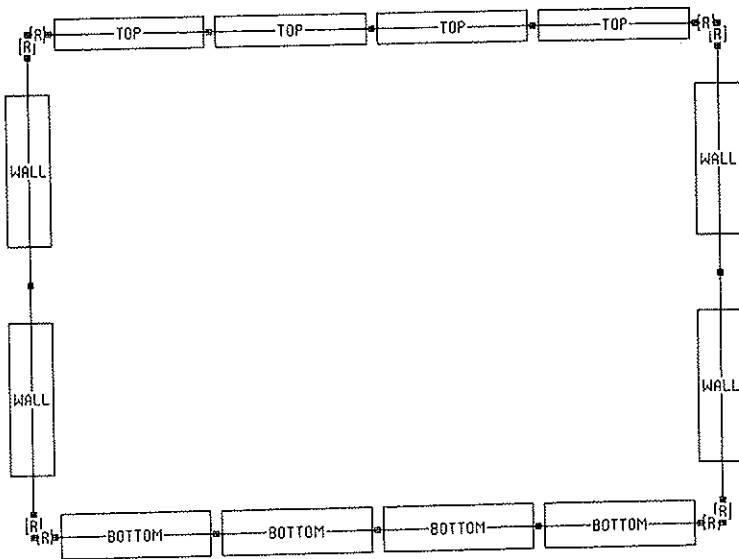

Plane (2-D) frame -analysis

 * STRUCTURAL - DATA *

Project title : ΜΕΤΑΤΡΟΠΗ ΕΓΚ/ΣΕΩΝ Α.Σ.Ο.-ΣΤΑΤΙΚΗ ΕΠΙΛΥΣΗ ΔΕΞΑΜΕΝΗΣ

JOINT DATA : (20 Joints)				Supports		Specialities
Joint	X [M]	Y [M]	Z [M]	V XYZ	R XYZ	
1	0.030000	0.000000	0.000000	F S	F	
2	0.180000	0.000000	0.000000			
12	4.480000	0.000000	0.000000			
13	4.630000	0.000000	0.000000	F S	F	
14	0.030000	0.000000	0.150000			
15	4.630000	0.000000	0.150000			
16	4.630000	0.000000	3.300000			
17	0.030000	0.000000	3.300000			
18	0.030000	0.000000	3.150000			
19	0.180000	0.000000	3.300000			
20	4.480000	0.000000	3.300000			
28	4.630000	0.000000	3.150000			
29	1.255000	0.000000	0.000000	F S	F	
30	2.330000	0.000000	0.000000	B S	F	
31	3.405000	0.000000	0.000000	F S	F	
32	0.030000	0.000000	1.650000			
33	4.630000	0.000000	1.650000			
34	1.255000	0.000000	3.300000			
35	2.330000	0.000000	3.300000			
36	3.405000	0.000000	3.300000			

ELASTICALLY SUPPORTED JOINTS: ("B"=Fixed "F"=Free)				R-X	R-Y	R-Z
Joint	V-X [KN/M]	V-Y [KN/M]	V-Z [KN/M]	[KNM/ARC]	[KNM/ARC]	[KNM/ARC]
1	F		2.000E+03			F
13	F		2.000E+03			F
29	F		3.750E+03			F
30	B		3.750E+03			F
31	F		3.750E+03			F

B A R D A T A : (20 bars)

Bar	Incidences		Length [M]	CS-Name (haunched)	Hinges		Specialities
	Start	End			start	end	
1	1	2	0.150000	%Q0001			mS
12	12	13	0.150000	%Q0001			mS
13*	1	14	0.150000	%Q0001			mS
14*	13	15	0.150000	%Q0001			mS
18*	18	17	0.150000	%Q0001			mS
19	17	19	0.150000	%Q0001			mS
21	20	16	0.150000	%Q0001			mS
31*	28	16	0.150000	%Q0001			mS
32	2	29	1.075000	BOTTOM			mS
33	29	30	1.075000	BOTTOM			mS
34	30	31	1.075000	BOTTOM			mS
35	31	12	1.075000	BOTTOM			mS
36*	14	32	1.500000	WALL			mS
37*	15	33	1.500000	WALL			mS
38*	32	18	1.500000	WALL			mS
39*	33	28	1.500000	WALL			mS
40	19	34	1.075000	TOP			mS
41	34	35	1.075000	TOP			mS
42	35	36	1.075000	TOP			mS
43	36	20	1.075000	TOP			mS

Bars marked with "*" are vertical (except any excentricities).
 The corresponding special definition for the default orientation
 of the local coordinate system applies.

mS = Bars with shear deformation

CROSS SECTION VALUES:

CS-Name	Ax [M2]	Iy [M4]	Fz [M2]
	z1 [M1]	zu [M1]	
%Q0001	1.0000E+02	1.0000E+02	1.0000E+02
(R)	-0.0500	0.0500	
BOTTOM	3.0000E-01	2.2500E-03	2.5000E-01
	-0.1500	0.1500	
TOP	2.0000E-01	6.6667E-04	1.6667E-01
	-0.1000	0.1000	
WALL	3.0000E-01	2.2500E-03	2.5000E-01
	-0.1500	0.1500	

	Ax [M2]	Iy [M4]	Fz [M2]
CS-Name	z1 [M1]	zu [M1]	

MATERIAL PROPERT. :

Bar (to bar)	E-Modulus [KN/ M2]	Shear-M [KN/ M2]
1 .. 43	2.9000E+07	1.2000E+07

STS-Run ok

cross section BOTTOM

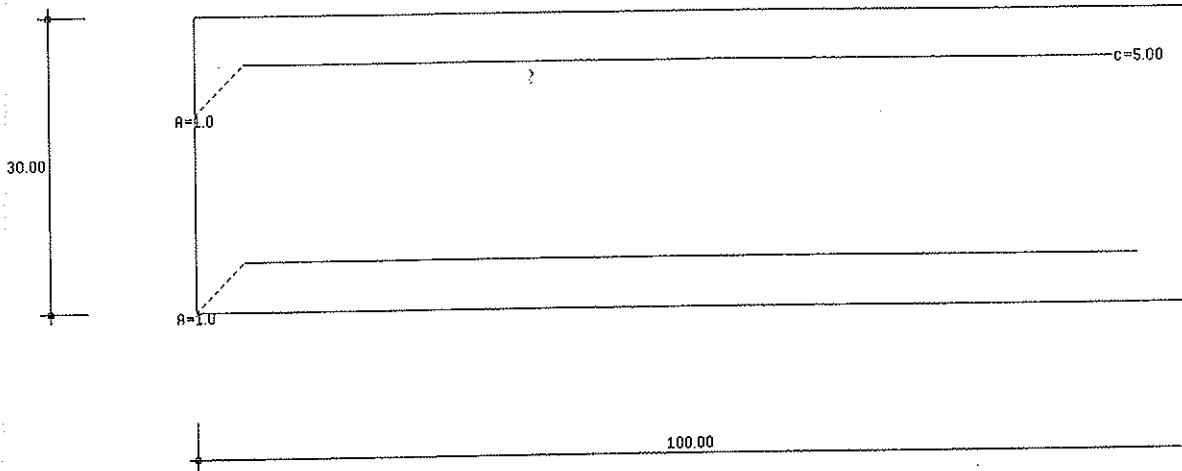

Geometrical definition of cross section "BOTTOM" (without weight factors)

Cross section	material	w	*ax[cm ²]	*u[cm]	*ix[cm ⁴]	Nr
R_TR	C20/25	1.00	3000.000	260.000	730013.7	1)
Boundary points [cm]:						
1	50.00	0.00	2	50.00	30.00	3 -50.00 30.00
4	-50.00	0.00				

Reinforcement "B_FIELD"		As-tot =2.00 cm ² (0.07 o/o)				
name	material	w	Code	A [cm ²]	y [cm]	z [cm]
MTOP / R_TR	S500	10.0	2	1.00	-45.00	25.00
					45.00	25.00
MBOTTOM / R_TR	S500	10.0	2	1.00	-45.00	5.00
					45.00	5.00

Shear wall action		width	height	y1	z1	y2	z2
SWZ1	Vz	100.00	20.00	0.00	25.00	0.00	5.00
SWY1	Vy	30.00	90.00	-45.00	15.00	45.00	15.00
SWT1	Torsion	100.00	30.00	0.00	0.00	0.00	30.00

Result points		result	unit	y[cm]	z [cm]
ASWZ		Res.Kmb.			
	Formula: ASW(SWZ1)				
ASWY		Res.Kmb.			
	Formula: ASW(SWY1)				
ASWT		Res.Kmb.			
	Formula: ASW(SWT1)				
ASW1		Res.Kmb.			

Formula: ASWY o ASWZ

Section properties of cross section "BOTTOM" (without weight factors)

Area	Ax = 3.000E3 cm2			
Moments of inertia	Iy = 225.00E3 cm4	Iz = 2.500E6 cm4	Ip = 2.725E6 cm4	
Torsional const.			Ix = 730.01E3 cm4	
Stat. moments	Zy = 22.50E3 cm3	Zz = 75.00E3 cm3		
Centroid of CS	ys = -0.00 cm	zs = 15.00 cm	angle = 0.0 deg	
Dist. from edges	yl = -50.00 cm	yr = 50.00 cm		
	zo = 15.00 cm	zu = -15.00 cm		

M-N-Reference point in the center of the cross section
V-T-Reference point in the center of the cross section

cross section TOP

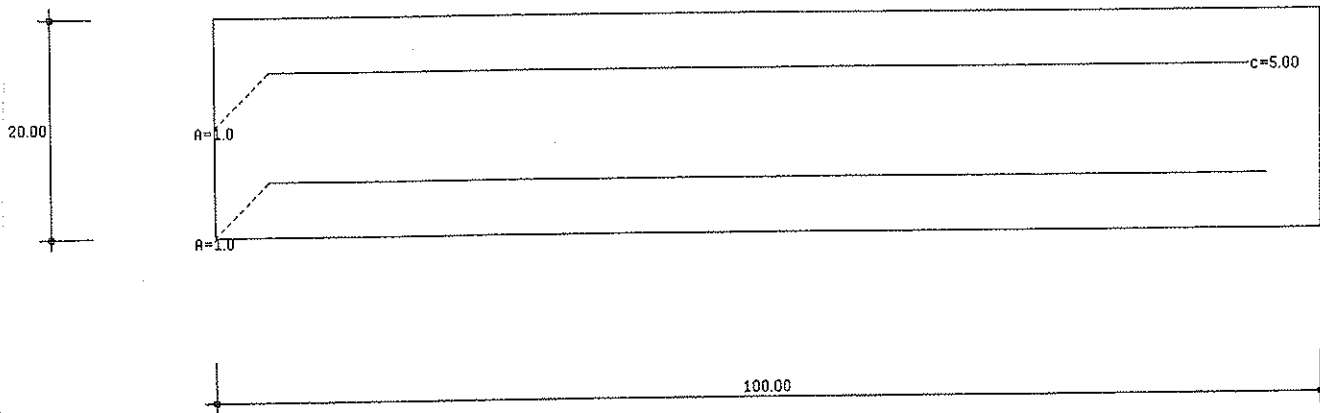

Geometrical definition of cross section "TOP" (without weight factors)

Cross section	material	w	*ax[cm ²]	*u[cm]	*ix[cm ⁴]	Nr
R_TR	C20/25	1.00	2000.000	240.000	233071.1	1)
Boundary points [cm]:						
1	50.00	0.00	2	50.00	20.00	3
4	-50.00	0.00				

Reinforcement "B_FIELD"		As-tot =2.00 cm ² (0.10 o/o)				
name	material	w	Code	A [cm ²]	y [cm]	z [cm]
MTOP / R_TR	S500	10.0	2	1.00	-45.00 45.00	15.00 15.00
MBOTTOM / R_TR	S500	10.0	2	1.00	-45.00 45.00	5.00 5.00

Shear wall action		width	height	y1	z1	y2	z2
SWZ1	Vz	100.00	10.00	0.00	15.00	0.00	5.00
SWY1	Vy	20.00	90.00	-45.00	10.00	45.00	10.00
SWT1	Torsion	100.00	20.00	0.00	0.00	0.00	20.00

Result points		result	unit	y[cm]	z [cm]
ASWZ		Res.Kmb.			
	Formula: ASW(SWZ1)				
ASWY		Res.Kmb.			
	Formula: ASW(SWY1)				
ASWT		Res.Kmb.			
	Formula: ASW(SWT1)				
ASW1		Res.Kmb.			
	Formula: ASWY o ASWZ				

Section properties of cross section "TOP" (without weight factors)

Area	Ax = 2.000E3 cm ²		
Moments of inertia	Iy = 66.67E3 cm ⁴	Iz = 1.667E6 cm ⁴	Ip = 1.733E6 cm ⁴
Torsional const.			Ix = 233.07E3 cm ⁴
Stat. moments	Zy = 10.00E3 cm ³	Zz = 50.00E3 cm ³	
Centroid of CS	ys = 0.00 cm	zs = 10.00 cm	angle = 0.0 deg
Dist. from edges	yl = -50.00 cm	yr = 50.00 cm	
	zo = 10.00 cm	zu = -10.00 cm	

M-N-Reference point in the center of the cross section
V-T-Reference point in the center of the cross section

cross section WALL

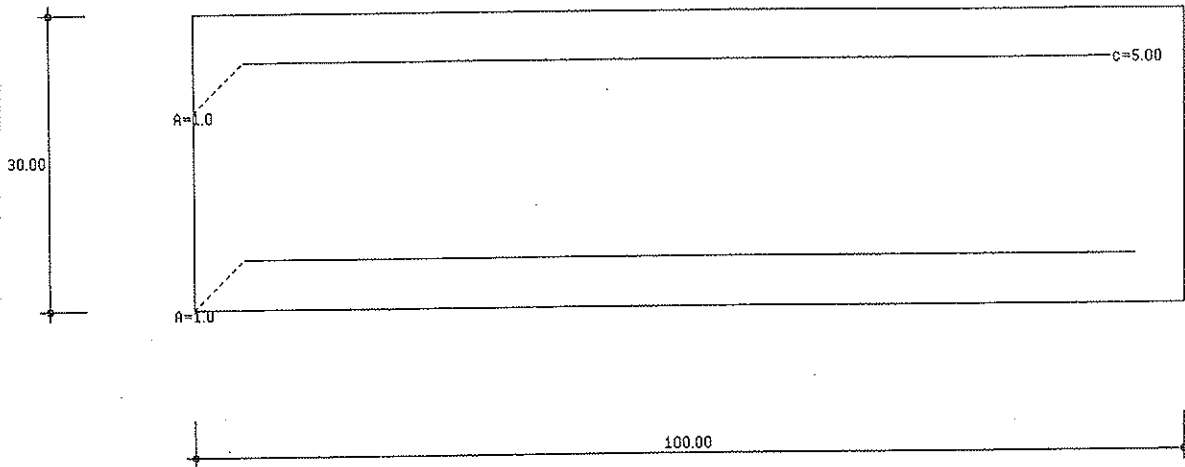

Geometrical definition of cross section "WALL" (without weight factors)

Cross section	material	w	*ax[cm2]	*u[cm]	*ix[cm4]	Nr
R_TR	C20/25	1.00	3000.000	260.000	730013.7	1)

Boundary points [cm]:

1	50.00	0.00	2	50.00	30.00	3	-50.00	30.00
4	-50.00	0.00						

Reinforcement "B_FIELD" $A_{s-tot} = 2.00 \text{ cm}^2$ (0.07 o/o)

name	material	w	Code	A [cm2]	y [cm]	z [cm]
MTOP / R_TR	S500	10.0	2	1.00	-45.00	25.00
					45.00	25.00
MBOTTOM / R_TR	S500	10.0	2	1.00	-45.00	5.00
					45.00	5.00

Shear wall action		width	height	y1	z1	y2	z2
SWZ1	Vz	100.00	20.00	0.00	25.00	0.00	5.00
SWY1	Vy	30.00	90.00	-45.00	15.00	45.00	15.00
SWT1	Torsion	100.00	30.00	0.00	0.00	0.00	30.00

Result points

Name / cross section	result	unit	y [cm]	z [cm]
ASWZ	Res.Kmb.			
ASWZ	Formula: ASW(SWZ1)			
ASWY	Res.Kmb.			
ASWY	Formula: ASW(SWY1)			
ASWT	Res.Kmb.			
ASWT	Formula: ASW(SWT1)			
ASW1	Res.Kmb.			

Formula: ASWY o ASWZ

Section properties of cross section "WALL" (without weight factors)

Area	Ax = 3.000E3 cm2			
Moments of inertia	Iy = 225.00E3 cm4	Iz = 2.500E6 cm4	Ip = 2.725E6 cm4	
Torsional const.			Ix = 730.01E3 cm4	
Stat. moments	Zy = 22.50E3 cm3	Zz = 75.00E3 cm3		
Centroid of CS	ys = -0.00 cm	zs = 15.00 cm	angle = 0.0 deg	
Dist. from edges	yl = -50.00 cm	yr = 50.00 cm		
	zo = 15.00 cm	zu = -15.00 cm		

M-N-Reference point in the center of the cross section
V-T-Reference point in the center of the cross section

LOAD COMBINATION CJ: ''

Loadcase	Factor	Stage	Init.def	Title
1	1.0000			SELF WEIGHT
2	1.0000			EARTH PRESSURES
4	1.0000			SHRINKING
5	1.0000			LIVE LOADS-H/M
8	1.0000			WATER PRESSURES OVERFLOW
15	1.0000			TEMPERATURE INCREASE
16	1.0000			TEMPERATURE DECREASE
17	1.0000			TEMPERATURE DIFF. DT1
18	1.0000			TEMPERATURE DIFF. DT2

=====
 Load case 1: SELF WEIGHT
 =====

Loadtype	Value (a)	Distanc Value (b)	Joint	-/member	numb
Mas.forcZ gl const.	-25.000		Stab	36	40
				34	33
				41	43
				38	37
					35
					32
					39

=====
 Load case 2: EARTH PRESSURES
 =====

Loadtype	Value (a)	Distanc Value (b)	Joint	-/member	numb
Force X gl trapez.	1.636	6.5E-0008			
from...to	0	0.150000	Stab		18
Force X gl trapez.	18.000	1.636			
from...to	0	1.500	Stab		38
Force X gl trapez.	34.364	18.000			
from...to	0	1.500	Stab		36
Force X gl trapez.	36.000	34.364			
from...to	0	0.150000	Stab		13
Force X gl trapez.	-1.636	-6.5E-0008			
from...to	0	0.150000	Stab		31
Force X gl trapez.	-18.000	-1.636			
from...to	0	1.500	Stab		39
Force X gl trapez.	-34.364	-18.000			
from...to	0	1.500	Stab		37
Force X gl trapez.	-36.000	-34.364			
from...to	0	0.150000	Stab		14

=====
 Load case 4: SHRINKING
 =====

Loadtype	Value(a)	Distanc Value(b)	Joint	-/member numb		
Strain X lo const.	-0.000150		Stab	36	40	35
			34	33	42	32
			41	43	37	39
			38			

=====
 Load case 5: LIVE LOADS-H/M
 =====

Loadtype	Value(a)	Distanc Value(b)	Joint	-/member numb		
Force Z gl const.	-3.000		Stab	19	21	40
			42	41	43	

=====
 Load case 8: WATER PRESSURES OVERFLOW
 =====

Loadtype	Value(a)	Distanc Value(b)	Joint	-/member numb		
Force Z gl const.	-30.000		Stab	35	34	33
			32			
Force X gl trapez.	15.000	0	Stab	39		
from...to	0	1.500				
Force X gl trapez.	30.000	15.000	Stab	37		
from...to	0	1.500				
Force X gl trapez.	-15.000	0	Stab	38		
from...to	0	1.500				
Force X gl trapez.	-30.000	-15.000	Stab	36		
from...to	0	1.500				

=====
 Load case 15: TEMPERATURE INCREASE
 =====

Loadtype	Value(a)	Distanc Value(b)	Joint	-/member numb		
Strain X lo const.	0.000300		Stab	36	40	35
			34	33	42	32
			41	43	37	39
			38			

=====
 Load case 16: TEMPERATURE DECREASE
 =====

Loadtype	Value(a)	Distanc Value(b)	Joint	-/member numb		
Strain X lo const.	-0.000100		Stab	36	40	35
			34	33	42	32
			41	43	37	39
			38			

=====
 Load case 17: TEMPERATURE DIFF. DT1
 =====

Loadtype	Value(a)	Distanc Value(b)	Joint	-/member numb		
Curvat. Y lo const.	0.000167		Stab	32 ..	35	
Curvat. Y lo const.	-0.000167		Stab	36		
Curvat. Y lo const.	0.000167		Stab	37		
Curvat. Y lo const.	-0.000167		Stab	38		
Curvat. Y lo const.	0.000167		Stab	39		
Curvat. Y lo const.	-0.000250		Stab	40 ..	43	

=====
 Load case 18: TEMPERATURE DIFF. DT2
 =====

Loadtype		Value(a)	Distanc Value(b)	Joint	-/member numb
Curvat. Y	lo const.	-0.000167		Stab	32 .. 35
Curvat. Y	lo const.	0.000167		Stab	36
Curvat. Y	lo const.	-0.000167		Stab	37
Curvat. Y	lo const.	0.000167		Stab	38
Curvat. Y	lo const.	-0.000167		Stab	39
Curvat. Y	lo const.	0.000250		Stab	40 .. 43

Scale 1 : 75.0
Load case 1

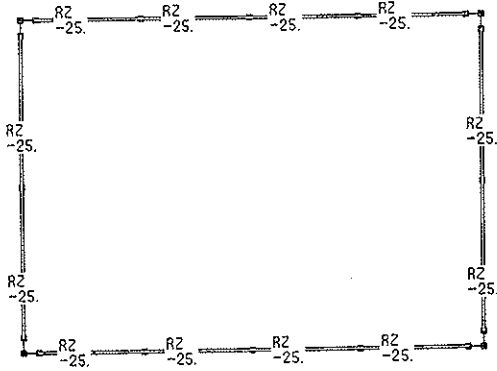

Scale 1 : 75.0
Load case 2

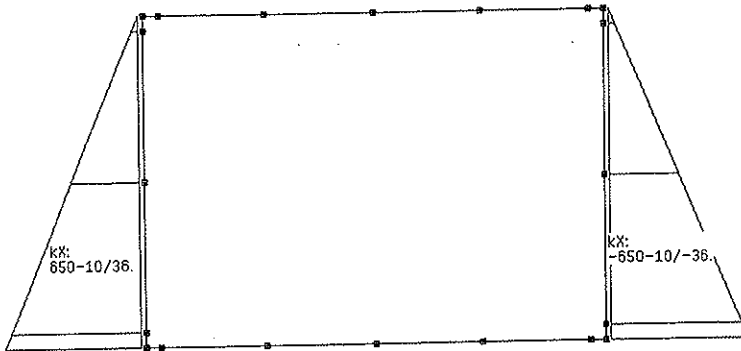

Scale 1 : 75.0
Load case 4

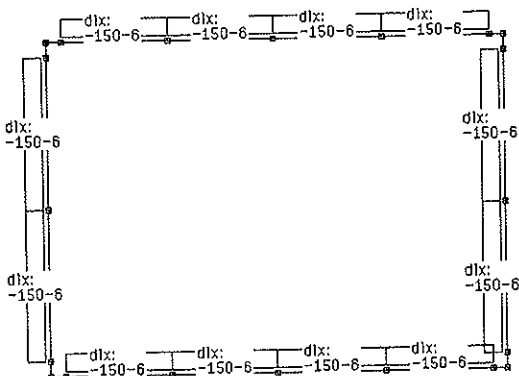

Scale 1 : 75.0
Load case 5

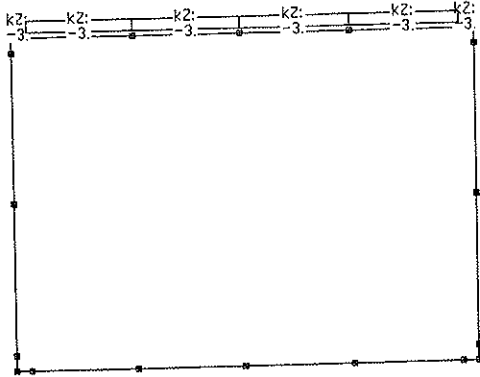

Scale 1 : 75.0
Load case 8

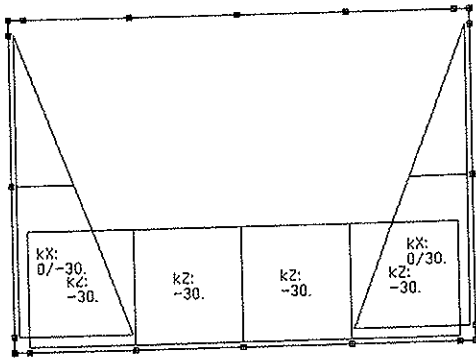

Scale 1 : 75.0
Load case 15

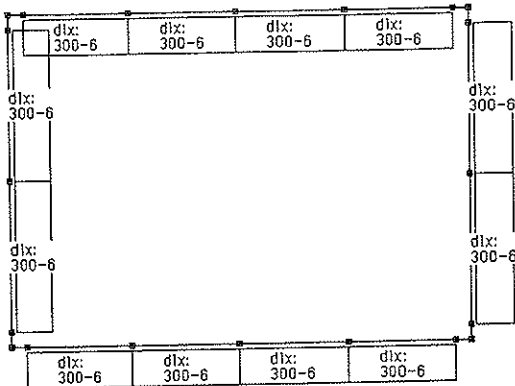

Scale 1 : 75.0
Load case 16

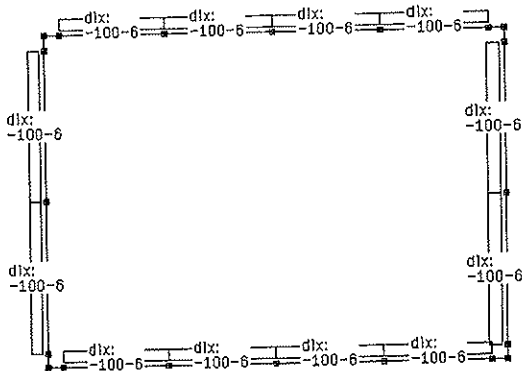

Scale 1 : 75.0
Load case 17

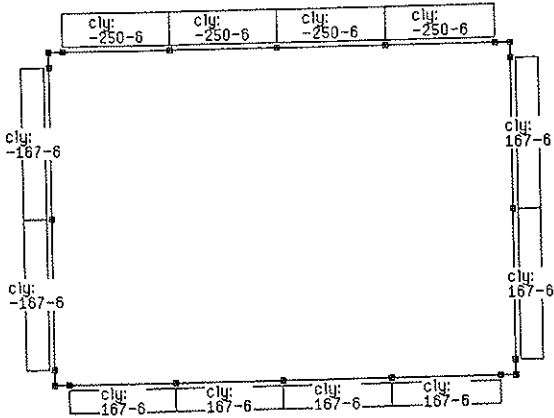

Scale 1 : 75.0
Load case 18

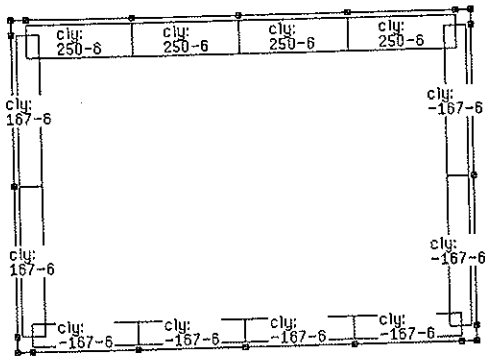

ENVELOPE SPECIFIC.: CK ''

Group	Spec.	Loadcase	Factor	Stage	Title
A	PERM.	1	1.000		SELF WEIGHT
	AND	2	1.000		EARTH PRESSURES
B	PLUS	4	1.000		SHRINKING
C	PLUS	5	1.000		LIVE LOADS-H/M
D	PLUS	8	1.000		WATER PRESSURES OVERFLOW
E	PLUS	15	1.000		TEMPERATURE INCREASE
F	OR	16	1.000		TEMPERATURE DECREASE
G	PLUS	17	1.000		TEMPERATURE DIFF. DT1
H	OR	18	1.000		TEMPERATURE DIFF. DT2

- Scale 1 : 34.7
 Displacements envelope DX [M], GWSP CK, Subsys. "ALL"
- Structure: Elmnts.
 - Minimum displacements DX, Scale: 5.0E2
 - Text minimum displacements DX [M]
 - Maximum displacements DX, Scale: 5.0E2
 - Text maximum displacements DX [M]
 - Label minimum value DX-Min. [M]
 - Label maximum value DX-Max. [M]

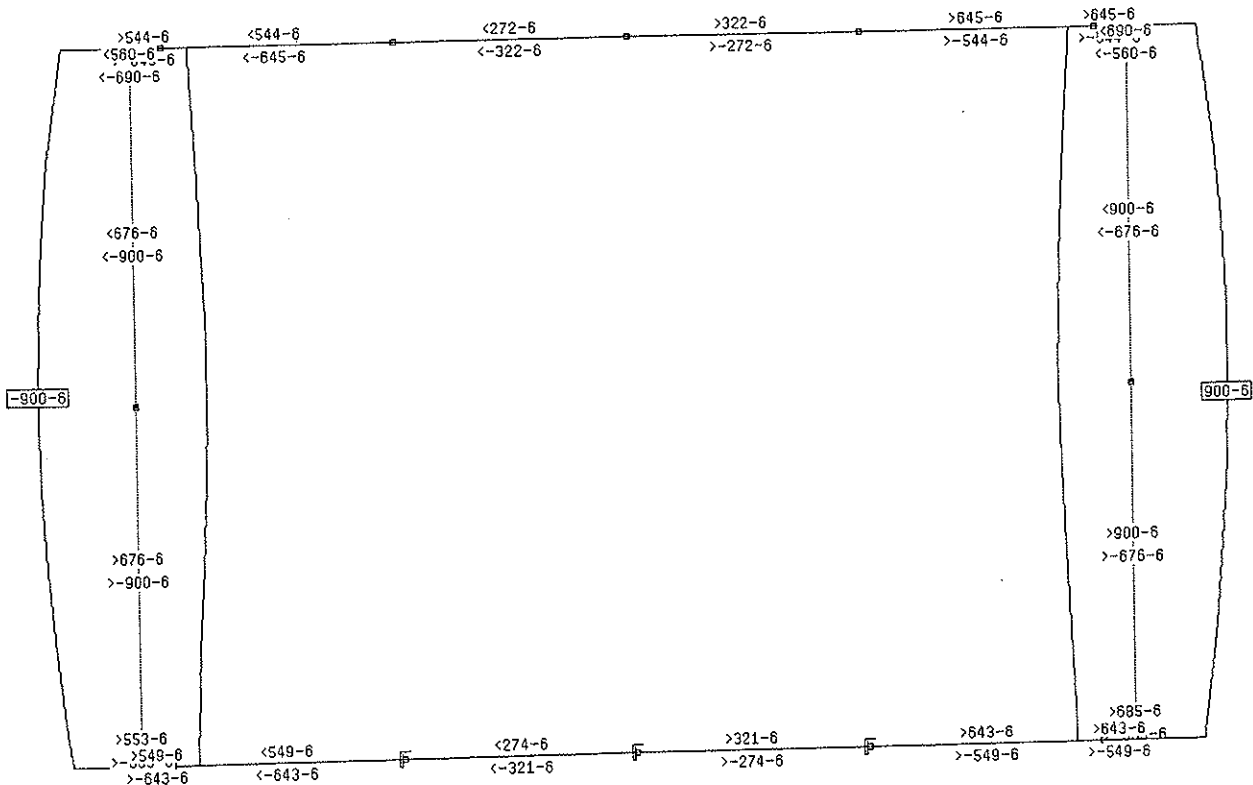

Scale 1 : 29.0

Displacements envelope DZ [M], GWSP CK, Subsys. "ALL"

- Structure: Elmnts.
- Minimum displacements DZ, Scale: 2.0E1
- Text minimum displacements DZ [M]
- Maximum displacements DZ, Scale: 2.0E1
- Text maximum displacements DZ [M]
- Label minimum value DZ-Min. [M]
- Label maximum value DZ-Max. [M]

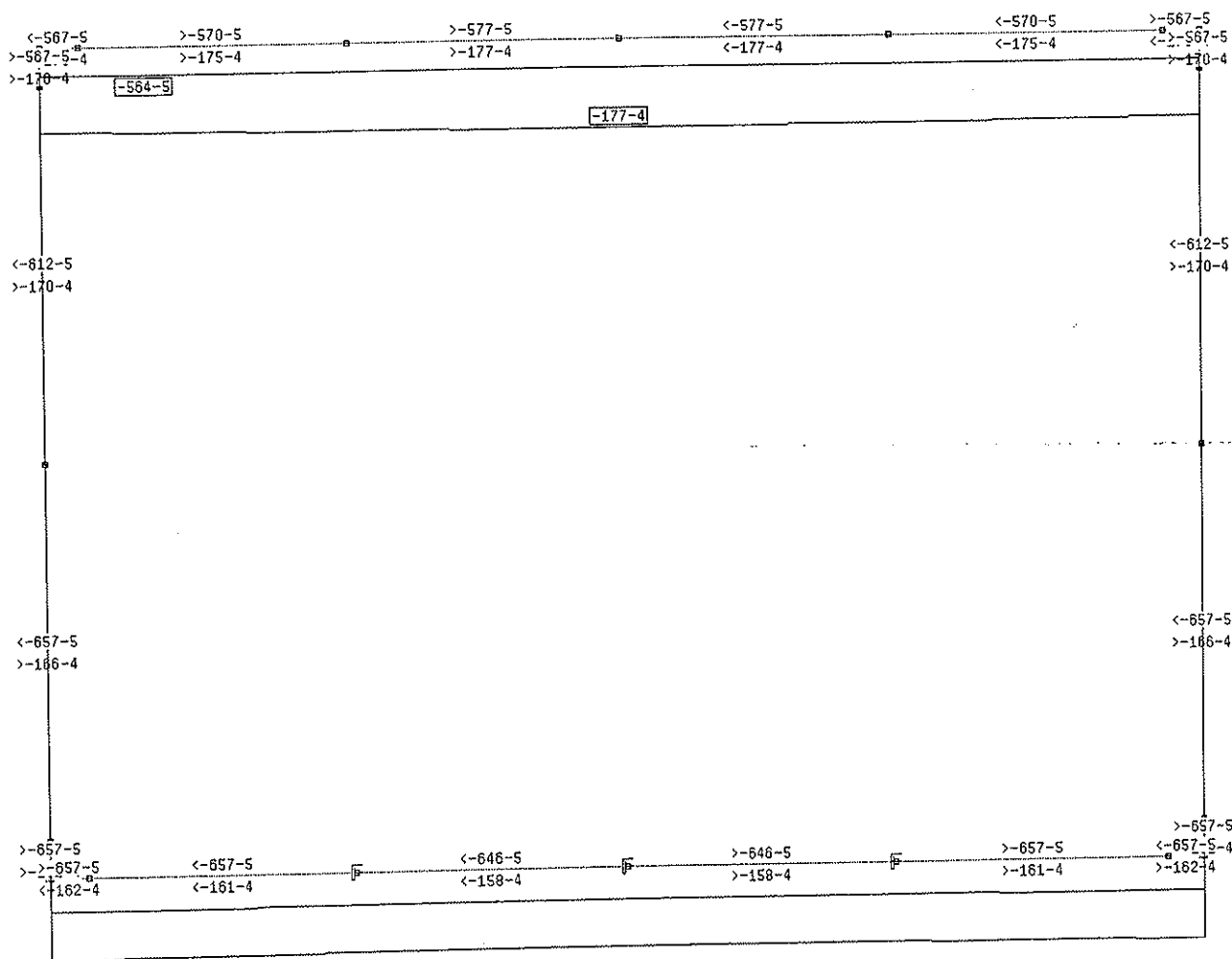

LOAD COMBINATION CL: 'Dead loads'

Loadcase	Factor	Stage	Init.def	Title
1	1.0000			SELF WEIGHT
2	1.0000			EARTH PRESSURES

ENVELOPE SPECIFIC.: CM 'Variable loads 1 (Design)'

Group	Spec.	Loadcase	Factor	Stage	Title
A		5	1.000		LIVE LOADS-H/M
B	PLUS	8	1.000		WATER PRESSURES OVERFLOW

ENVELOPE SPECIFIC.: CN 'Variable loads 3 (Design)'

Group	Spec.	Loadcase	Factor	Stage	Title
A		4	1.000		SHRINKING
B	PLUS	15	1.000		TEMPERATURE INCREASE
C	OR	16	1.000		TEMPERATURE DECREASE
D	PLUS	17	1.000		TEMPERATURE DIFF. DT1
E	OR	18	1.000		TEMPERATURE DIFF. DT2

SPECIFICATINS DESIGN ENVELOPE File:EDSTD, 'Design'

Load group	Char.Actions	Factor	File
1	Dead loads	1.350	(SDESTD)
	Variable loads 1 (Design)	1.500	(GD1STD)
	Variable loads 3 (Design)	1.500	(GD3STD)
OR			
2	Dead loads	1.350	(SDESTD)
	Variable loads 1 (Design)	1.500	(GD1STD)
	Variable loads 3 (Design)	1.500	(GD3STD)
OR			
3	Dead loads	1.000	(SDESTD)
	Variable loads 1 (Design)	1.500	(GD1STD)
	Variable loads 3 (Design)	1.500	(GD3STD)
OR			
4	Dead loads	1.000	(SDESTD)
	Variable loads 1 (Design)	1.500	(GD1STD)
	Variable loads 3 (Design)	1.500	(GD3STD)

FAGUS-3 - post-processor module::
 Section forces restored from STATIK-3

Section forces restored from STATIK-3:							
Analysis	C.Set	N	Vy	Vz	T	My	Mz
Design	2	EDSTD	.	EDSTD	.	EDSTD	.

Calculation parameters Construction code: GR-Norm 95

Calculation set 2: Design(Standard)

Concrete stress strain diagram type 2
 Concrete in tension type 0

Max. strains:
 Max. concrete strain at ult. limit state (compr.) -2.00 [o/oo]
 Max. concrete strain at ult. limit state (bending) -3.50 [o/oo]
 Max. strain in reinforcement bars (ult.limit state) 20.00 [o/oo]

Resistance coefficients:
 Concrete..... 1.5
 Steel..... 1.15
 Prestressing steel..... 1.15
 Structural steel..... 1.15

Inclination of diagonal in compression..... 45
 Creep coefficient..... 0

Scale 1 : 75.0

Int. Forces envelope N , Design, Subsys. "LIST"

- Structure: Elmnts.
- Envelope Normal force N-min, Scale 1.00E-02
min: -6.21E+01 max: -2.48E+01 [kN]
- Envelope Normal force N-max, Scale 1.00E-02
min: -3.33E+01 max: 8.42E+00 [kN]
- Text envelopes [kN]

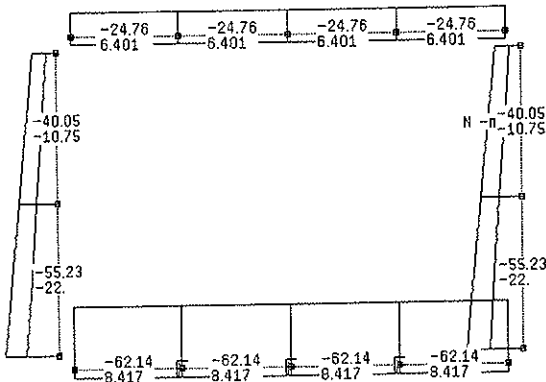

Scale 1 : 75.0

Int. Forces envelope Vz, Design, Subsys. "LIST"

- Structure: Elmnts.
- Envelope Shear force Vz-min, Scale 5.00E-03
min: -6.80E+01 max: 2.81E+01 [kN]
- Envelope Shear force Vz-max, Scale 5.00E-03
min: -2.81E+01 max: 6.80E+01 [kN]
- Text envelopes [kN]

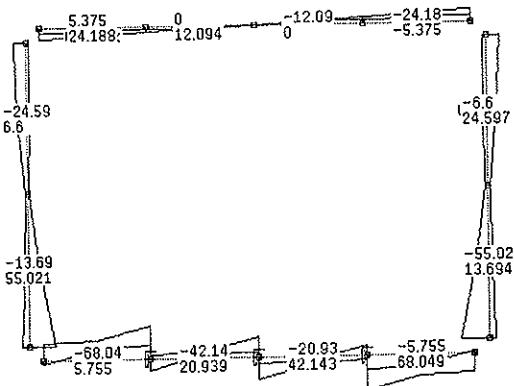

Scale 1 : 75.0
 Int. Forces envelope My, Design, Subsys. "LIST"
 - Structure: Elmnts.
 - Envelope Moment My-min, Scale 1.00E-02
 min: -5.47E+01 max: -1.27E+00 [kNm]
 - Envelope Moment My-max, Scale 1.00E-02
 min: 1.27E+00 max: 4.89E+01 [kNm]
 - Text envelopes [kNm]

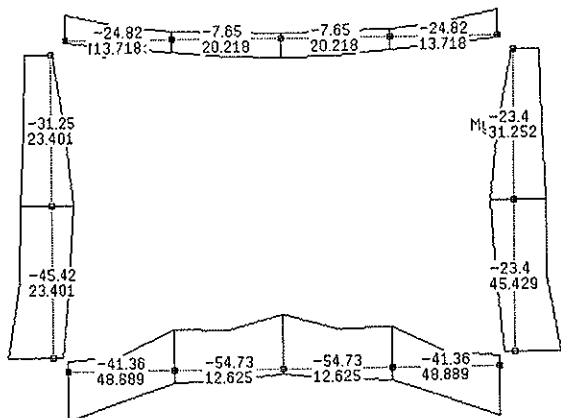

Scale 1 : 75.0
 Calcul. As, , Subsys. "LIST"
 - Structure: Elmnts.
 - Longit.reinf As-upper-tot, Scale 1.00E-01
 min: 1.00E+00 max: 5.56E+00 [cm2]
 - Longit.reinf As-lower-tot, Scale 1.00E-01
 min: 1.00E+00 max: 4.18E+00 [cm2]
 - Text As-upper, As-lower, As-stirrups-z(y) [cm2/m]

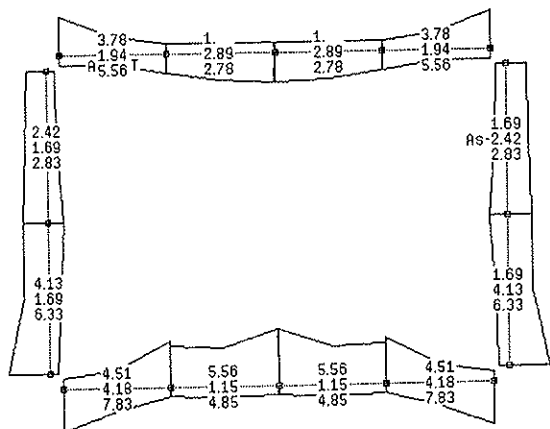

ΣΕΙΣΜΙΚΗ ΕΠΙΛΥΣΗ ΔΕΞΑΜΕΝΗΣ

LOAD COMBINATION CD: ''

Loadcase	Factor	Stage	Init.def	Title
20	1.0000			E/Q E/PRESSURES
21	1.0000			E/Q E/PRESSURES+
22	1.0000			E/Q E/PRESSURES-
23	1.0000			E/Q WATER PRESSURES
24	1.0000			E/Q WATER PRESSURES (R)
25	1.0000			INERTIA X
26	1.0000			INERTIA Z
27	1.0000			E/Q WATER PRESSURES Z

Scale 1 : 75.0
Load case 20

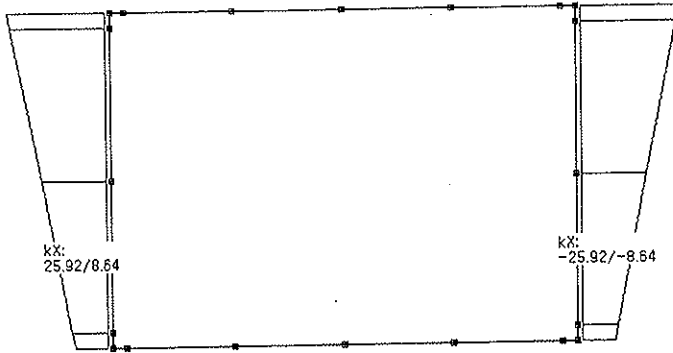

Scale 1 : 75.0
Load case 21

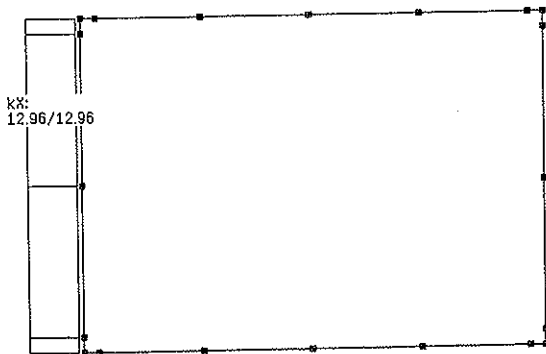

Scale 1 : 75.0
Load case 22

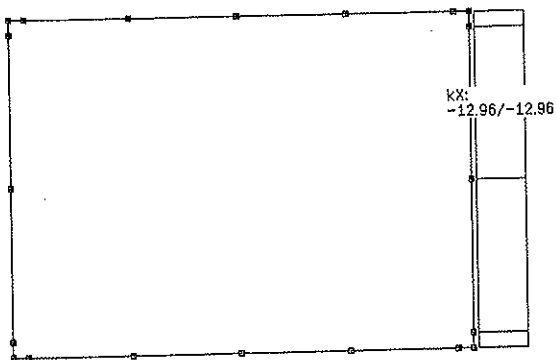

Scale 1 : 75.0
Load case 23

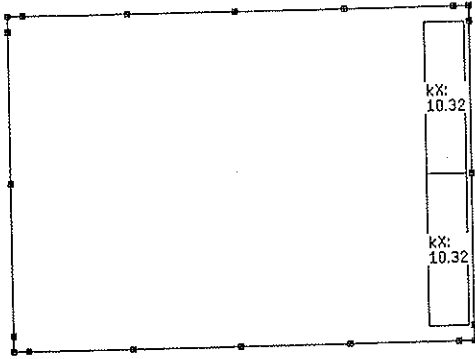

Scale 1 : 75.0
Load case 24

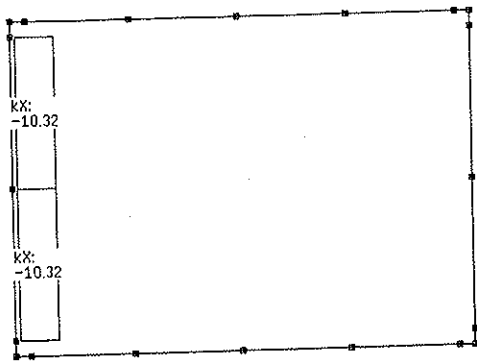

Scale 1 : 75.0
Load case 25

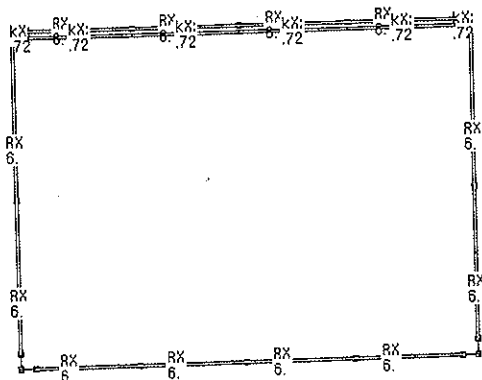

Scale 1 : 75.0
Load case 26

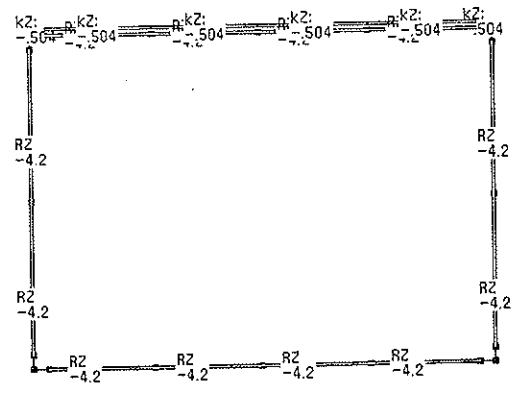

Scale 1 : 75.0
Load case 27

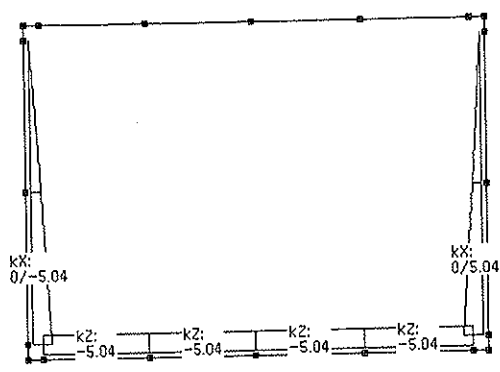

Scale 1 : 31.8

Displacements envelope DX [M], GWSP CE, Subsys. "ALL"

- Structure: Elmnts.
- Minimum displacements DX, Scale: 2.0E1
- Text minimum displacements DX [M]
- Maximum displacements DX, Scale: 2.0E1
- Text maximum displacements DX [M]
- Label minimum value DX-Min. [M]
- Label maximum value DX-Max. [M]

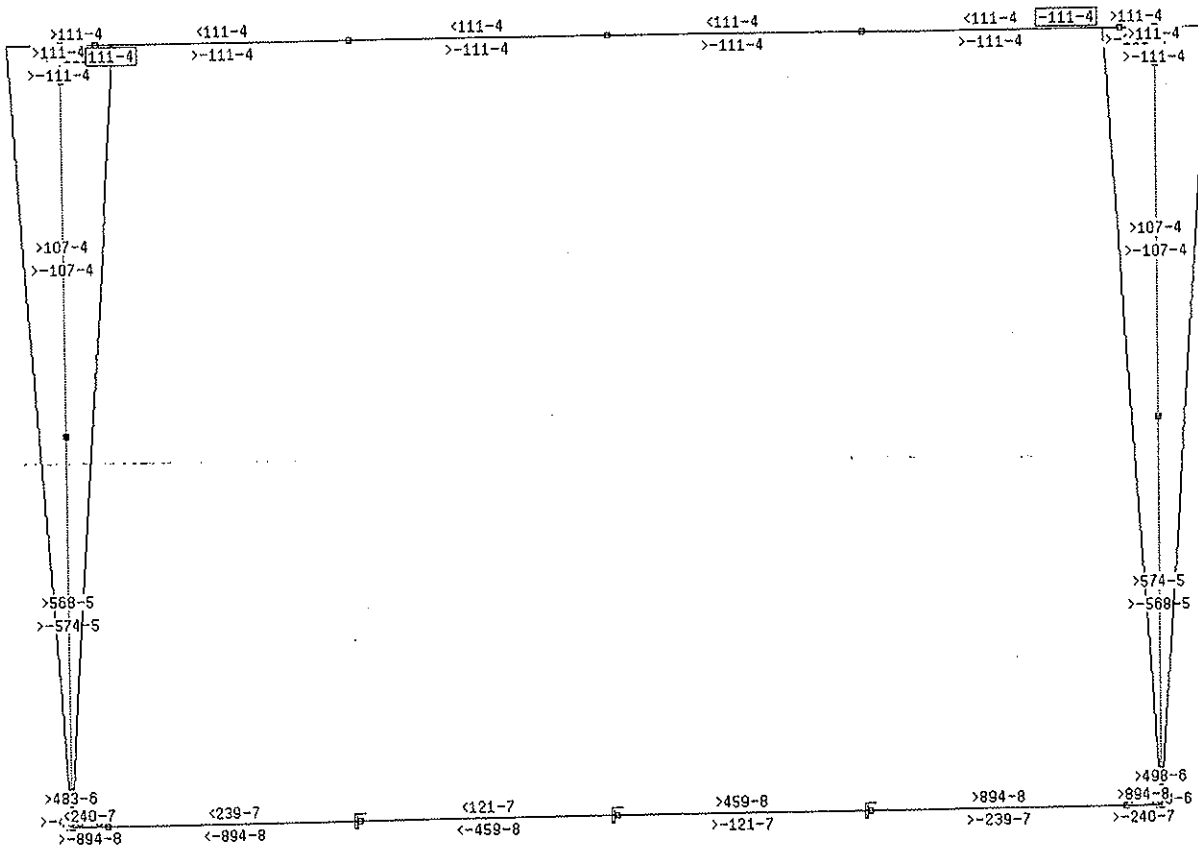

Scale 1 : 29.0

Displacements envelope DZ [M], GWSP CE, Subsys. "ALL"

- Structure: Elmnts.
- Minimum displacements DZ, Scale: 2.0E1
- Text minimum displacements DZ [M]
- Maximum displacements DZ, Scale: 2.0E1
- Text maximum displacements DZ [M]
- Label minimum value DZ-Min. [M]
- Label maximum value DZ-Max. [M]

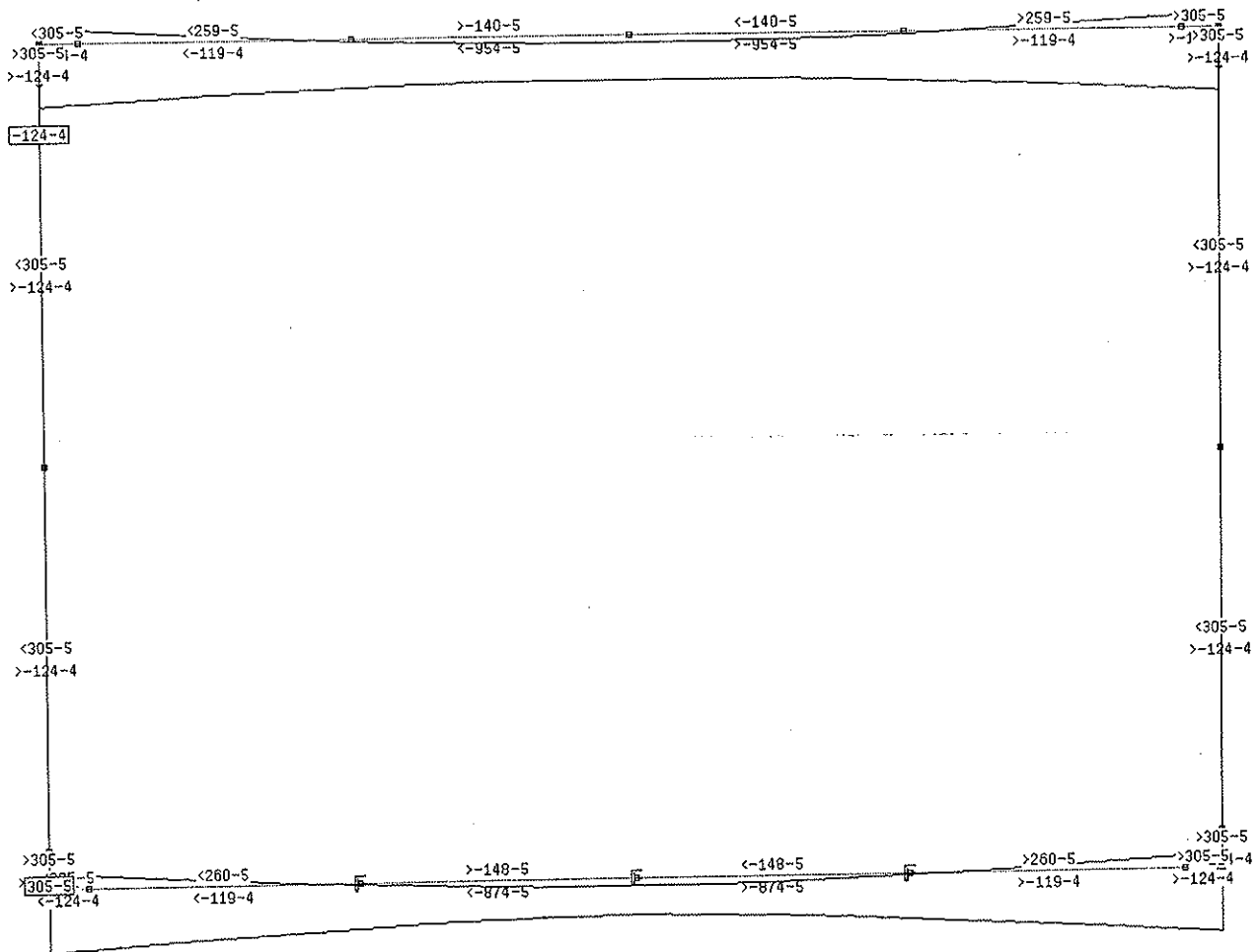

LOAD COMBINATION CF: 'Dead loads'

Loadcase	Factor	Stage	Init.def	Title
1	1.0000			SELF WEIGHT
2	1.0000			EARTH PRESSURES

ENVELOPE SPECIFIC.: CG 'Variable loads 1 (Design)'

Group	Spec.	Loadcase	Factor	Stage	Title
A		5	1.000		LIVE LOADS-H/M
B	PLUS	8	1.000		WATER PRESSURES OVERFLOW

ENVELOPE SPECIFIC.: CH 'Variable loads 2 (Design)'

Group	Spec.	Loadcase	Factor	Stage	Title
A		20	1.000		E/Q E/PRESSURES
B	OR	21	1.000		E/Q E/PRESSURES+
	AND	23	1.000		E/Q WATER PRESSURES
	AND	25	1.000		INERTIA X
C	OR	22	1.000		E/Q E/PRESSURES-
	AND	24	1.000		E/Q WATER PRESSURES (R)
	AND	25	-1.000		INERTIA X
D	PLUS	26	0.300000		INERTIA Z
	AND	27	0.300000		E/Q WATER PRESSURES Z
E	OR	26	-0.300000		INERTIA Z
	AND	27	-0.300000		E/Q WATER PRESSURES Z

ALTERNATIVE ENVELOPE :

F		26	1.000		INERTIA Z
	AND	27	1.000		E/Q WATER PRESSURES Z
G	OR	26	-1.000		INERTIA Z
	AND	27	-1.000		E/Q WATER PRESSURES Z
H	PLUS	20	0.300000		E/Q E/PRESSURES
I	OR	21	0.300000		E/Q E/PRESSURES+
	AND	23	0.300000		E/Q WATER PRESSURES
	AND	25	0.300000		INERTIA X
J	OR	22	0.300000		E/Q E/PRESSURES-
	AND	24	0.300000		E/Q WATER PRESSURES (R)
	AND	25	-0.300000		INERTIA X

SPECIFICATINS DESIGN ENVELOPE File:EDSTD, 'Design'
=====

Load group	Char.Actions	Factor	File
1	Dead loads	1.000	(SDESTD)
	Variable loads 1 (Design)	1.000	(GD1STD)
	Variable loads 2 (Design)	1.000	(GD2STD)

Scale 1 : 75.0

Int. Forces envelope N , GWSP CH (Variable loads 2 (Design)), Subsys. "LIS

- Structure: Elmnts.
- Envelope Normal force N-min, Scale 1.00E-02
min: -5.50E+01 max: -1.19E+01 [kN]
- Envelope Normal force N-max, Scale 1.00E-02
min: 2.35E+00 max: 4.88E+01 [kN]
- Text envelopes [kN]

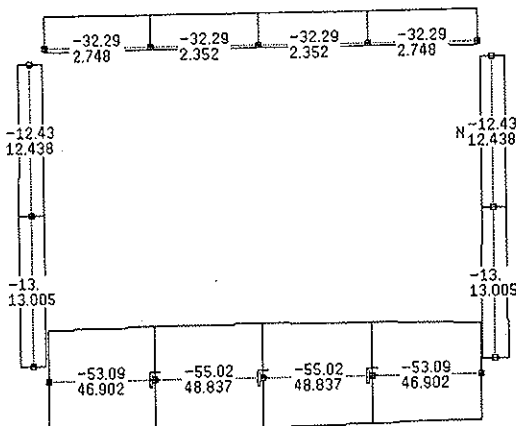

Scale 1 : 75.0

Int. Forces envelope Vz, GWSP CH (Variable loads 2 (Design)), Subsys. "LIS

- Structure: Elmnts.
- Envelope Shear force Vz-min, Scale 1.00E-02
min: -4.92E+01 max: -4.08E+00 [kN]
- Envelope Shear force Vz-max, Scale 1.00E-02
min: 4.08E+00 max: 4.92E+01 [kN]
- Text envelopes [kN]

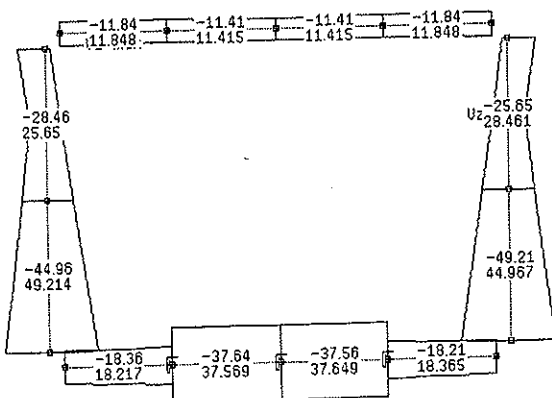

Scale 1 : 75.0

Int. Forces envelope My, GWSP CH (Variable loads 2 (Design)), Subsys. "LI

- Structure: Elmnts.
- Envelope Moment My-min, Scale 1.00E-02
min: -5.56E+01 max: -3.20E+00 [kNm]
- Envelope Moment My-max, Scale 1.00E-02
min: 1.80E+00 max: 5.69E+01 [kNm]
- Text envelopes [kNm]

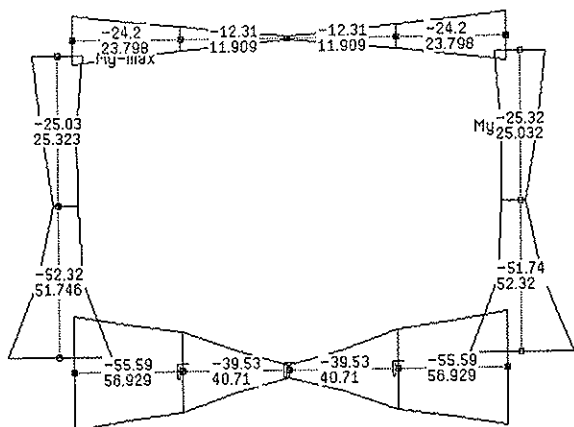

Scale 1 : 75.0

Calcul. As, , Subsys. "LIST"

- Structure: Elmnts.
- Longit.reinf As-upper-tot, Scale 5.00E-02
min: 1.00E+00 max: 7.62E+00 [cm2]
- Longit.reinf As-lower-tot, Scale 5.00E-02
min: 1.00E+00 max: 7.62E+00 [cm2]
- Text As-upper, As-lower, As-stirrups-z(y) [cm2/m]

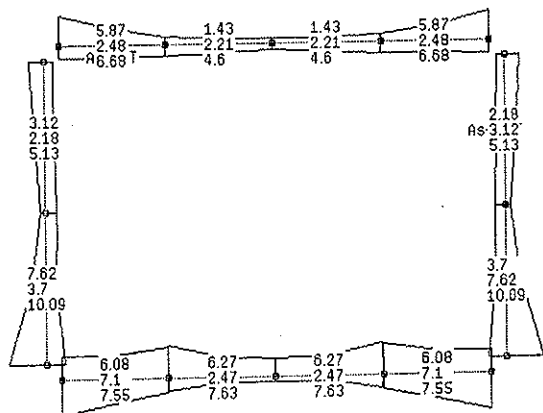

ΣΤΑΤΙΚΗ ΕΠΙΛΥΣΗ ΑΝΤΛΙΟΣΤΑΣΙΟΥ

Scale 1 : 30.9
Structure - MODEL

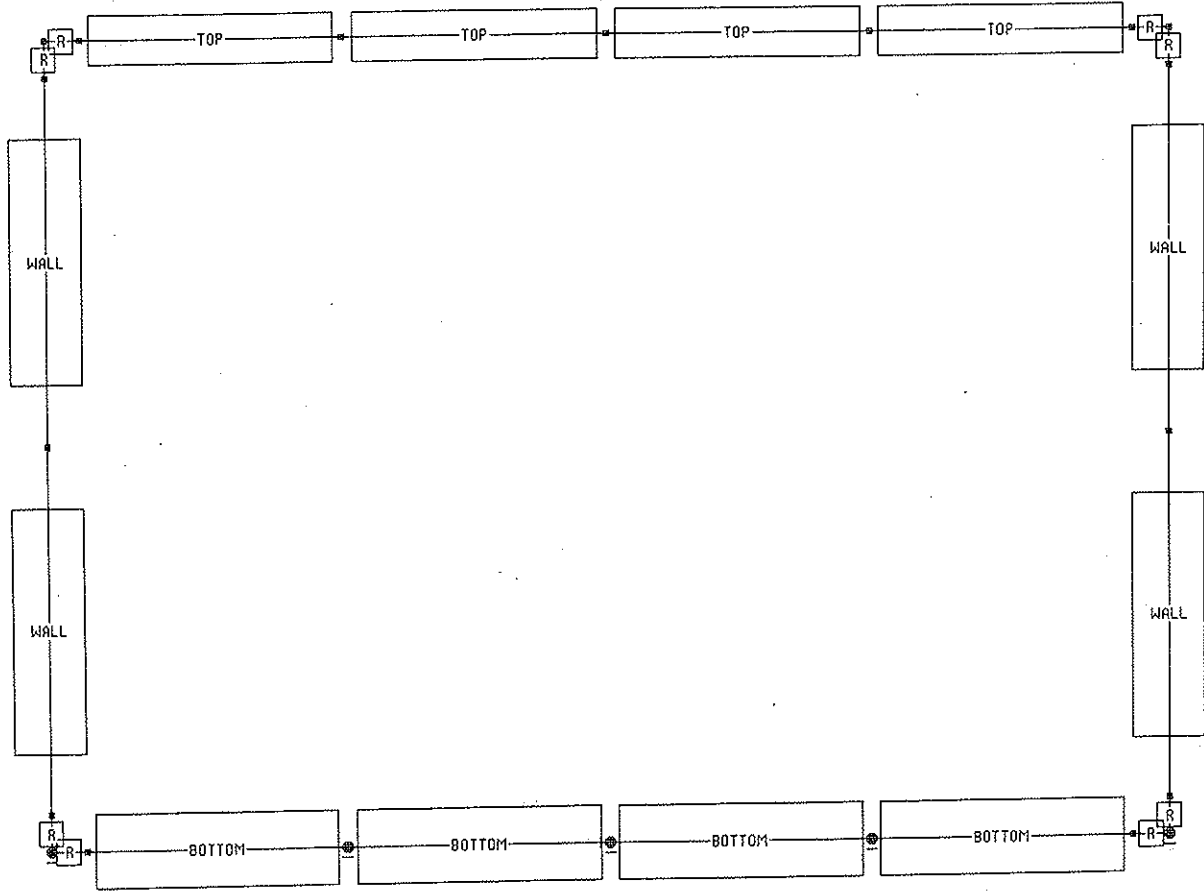

LOAD COMBINATION CM: ' '

Loadcase	Factor	Stage	Init.def	Title
1	1.0000			SELF WEIGHT
2	1.0000			EARTH PRESSURES
4	1.0000			SHRINKING
5	1.0000			LIVE LOADS-H/M
15	1.0000			TEMPERATURE INCREASE
16	1.0000			TEMPERATURE DECREASE
17	1.0000			TEMPERATURE DIFF. DT1
18	1.0000			TEMPERATURE DIFF. DT2

Scale 1 : 75.0
Load case 1

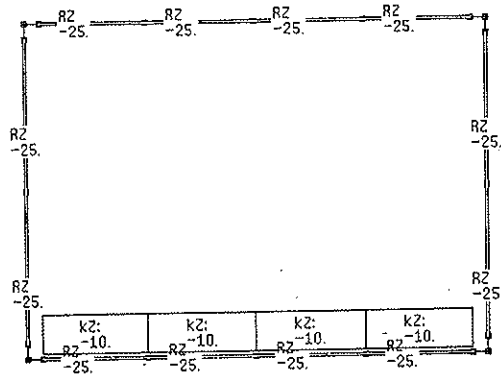

Scale 1 : 75.0
Load case 2

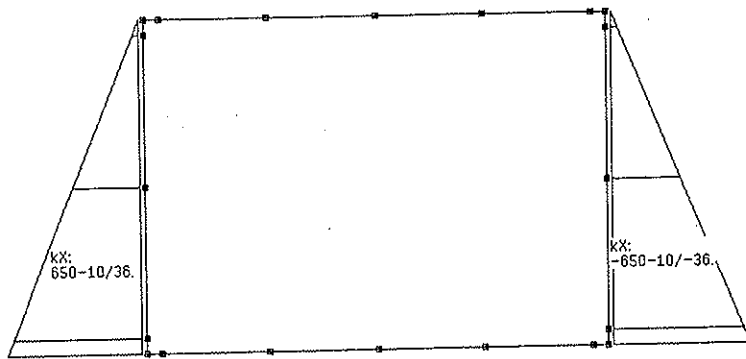

Scale 1 : 75.0
Load case 4

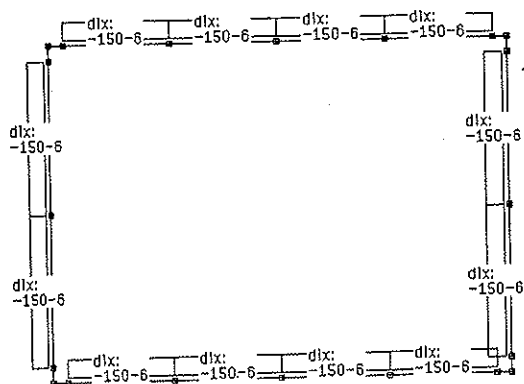

Scale 1 : 75.0

Load case 5

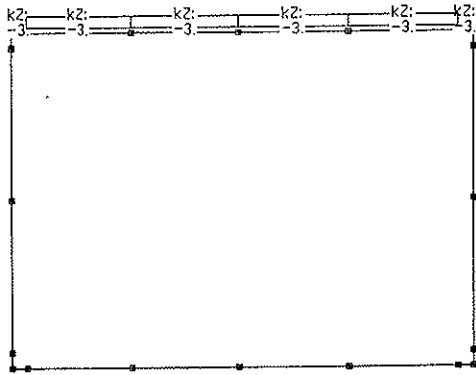

Scale 1 : 75.0

Load case 15

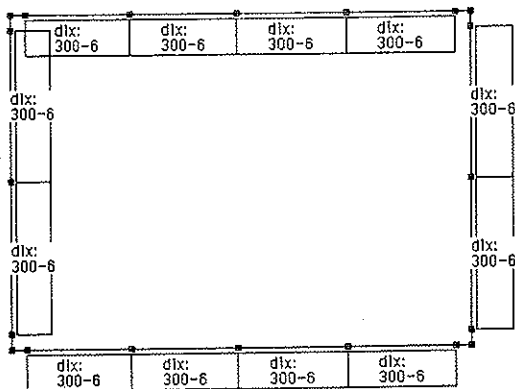

Scale 1 : 75.0
Load case 16

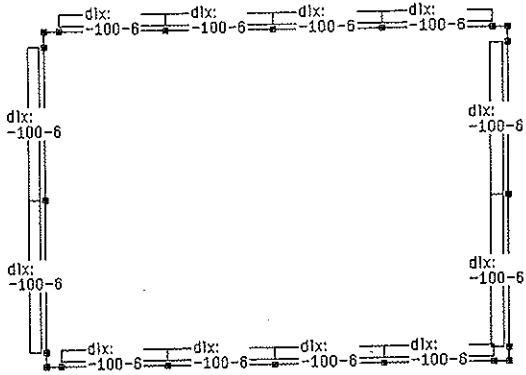

Scale 1 : 75.0
Load case 17

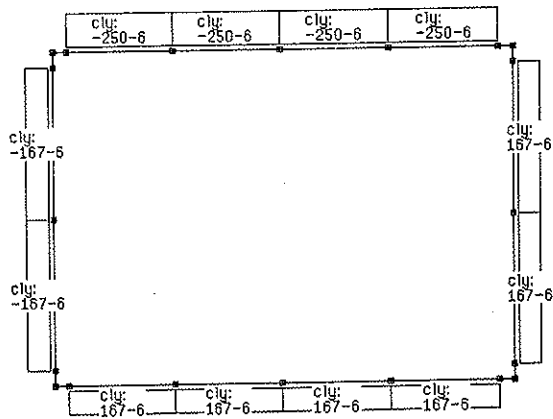

Scale 1 : 75.0

Load case 18

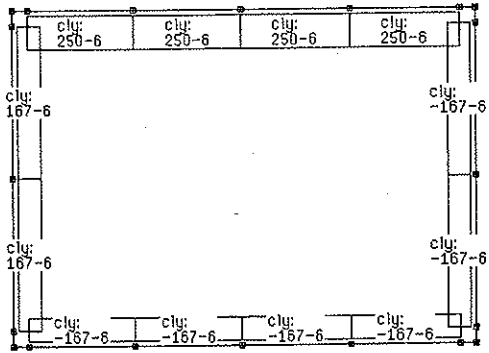

Scale 1 : 29.0

Displacements envelope DZ [M], GWSP CN, Subsys. "ALL"

- Structure: Elmnts.
- Minimum displacements DZ, Scale: 2.0E1
- Text minimum displacements DZ [M]
- Maximum displacements DZ, Scale: 2.0E1
- Text maximum displacements DZ [M]
- Label minimum value DZ-Min. [M]
- Label maximum value DZ-Max. [M]

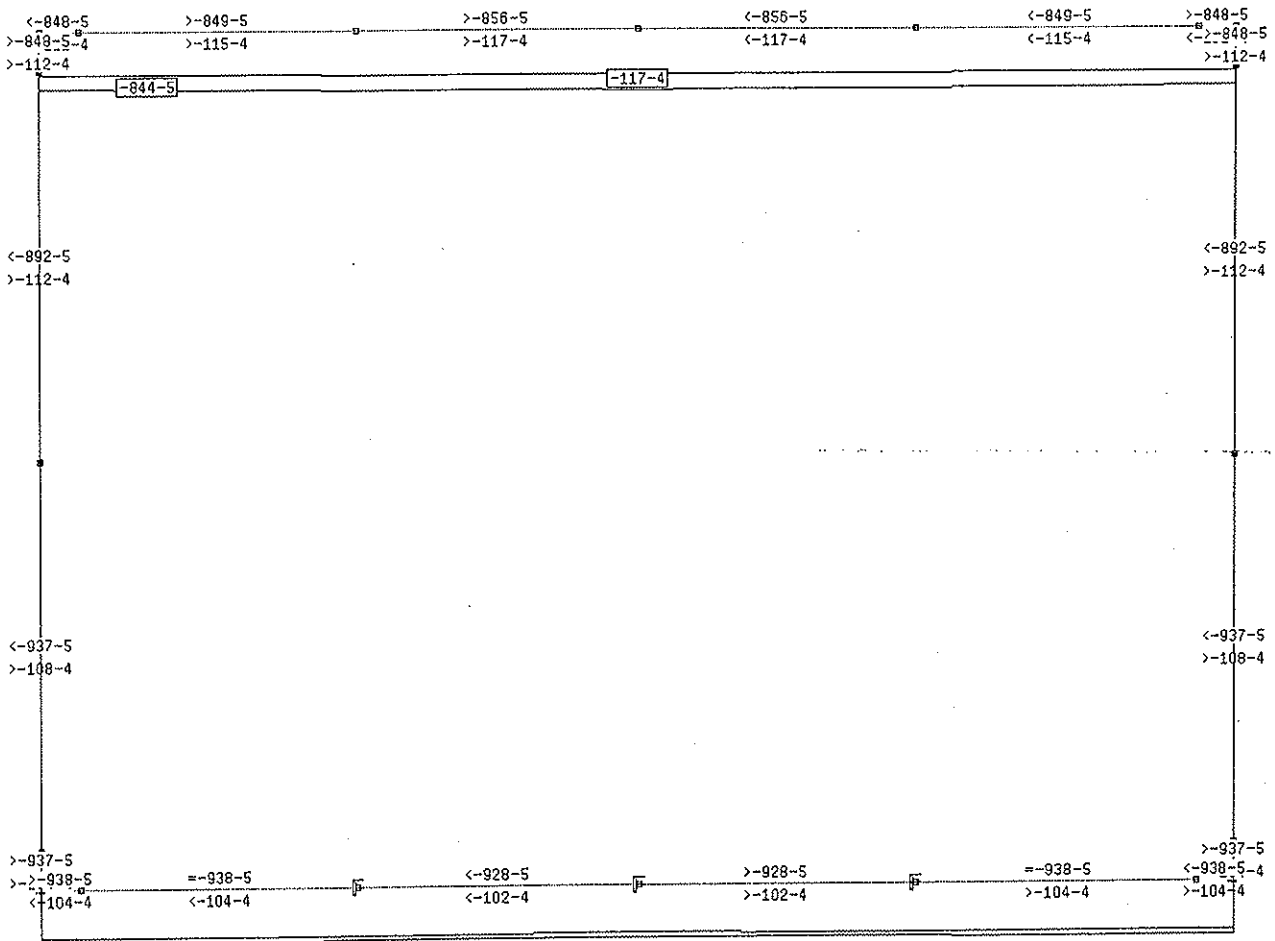

LOAD COMBINATION CO: 'Dead loads'

Loadcase	Factor	Stage	Init.def	Title
1	1.0000			SELF WEIGHT
2	1.0000			EARTH PRESSURES

ENVELOPE SPECIFIC.: CP 'Variable loads 1 (Design)'

Group	Spec.	Loadcase	Factor	Stage	Title
A		5	1.000		LIVE LOADS-H/M

ENVELOPE SPECIFIC.: CQ 'Variable loads 3 (Design)'

Group	Spec.	Loadcase	Factor	Stage	Title
A		4	1.000		SHRINKING
B	PLUS	15	1.000		TEMPERATURE INCREASE
C	OR	16	1.000		TEMPERATURE DECREASE
D	PLUS	17	1.000		TEMPERATURE DIFF. DT1
E	OR	18	1.000		TEMPERATURE DIFF. DT2

SPECIFICATINS DESIGN ENVELOPE File:EDSTD, 'Design'

Load group	Char.Actions	Factor	File
1	Dead loads	1.350	(SDESTD)
	Variable loads 1 (Design)	1.500	(GD1STD)
	Variable loads 3 (Design)	1.500	(GD3STD)
OR			
2	Dead loads	1.350	(SDESTD)
	Variable loads 1 (Design)	1.500	(GD1STD)
	Variable loads 3 (Design)	1.500	(GD3STD)
OR			
3	Dead loads	1.000	(SDESTD)
	Variable loads 1 (Design)	1.500	(GD1STD)
	Variable loads 3 (Design)	1.500	(GD3STD)
OR			
4	Dead loads	1.000	(SDESTD)
	Variable loads 1 (Design)	1.500	(GD1STD)
	Variable loads 3 (Design)	1.500	(GD3STD)

Scale 1 : 32.5

Int. Forces envelope N , Design, Subsys. "LIST"

- Structure: Elmnts.
- Envelope Normal force N-min, Scale 1.00E-02
min: -6.15E+01 max: -2.49E+01 [kN]
- Envelope Normal force N-max, Scale 1.00E-02
min: -3.96E+01 max: -1.08E+01 [kN]
- Text envelopes [kN]

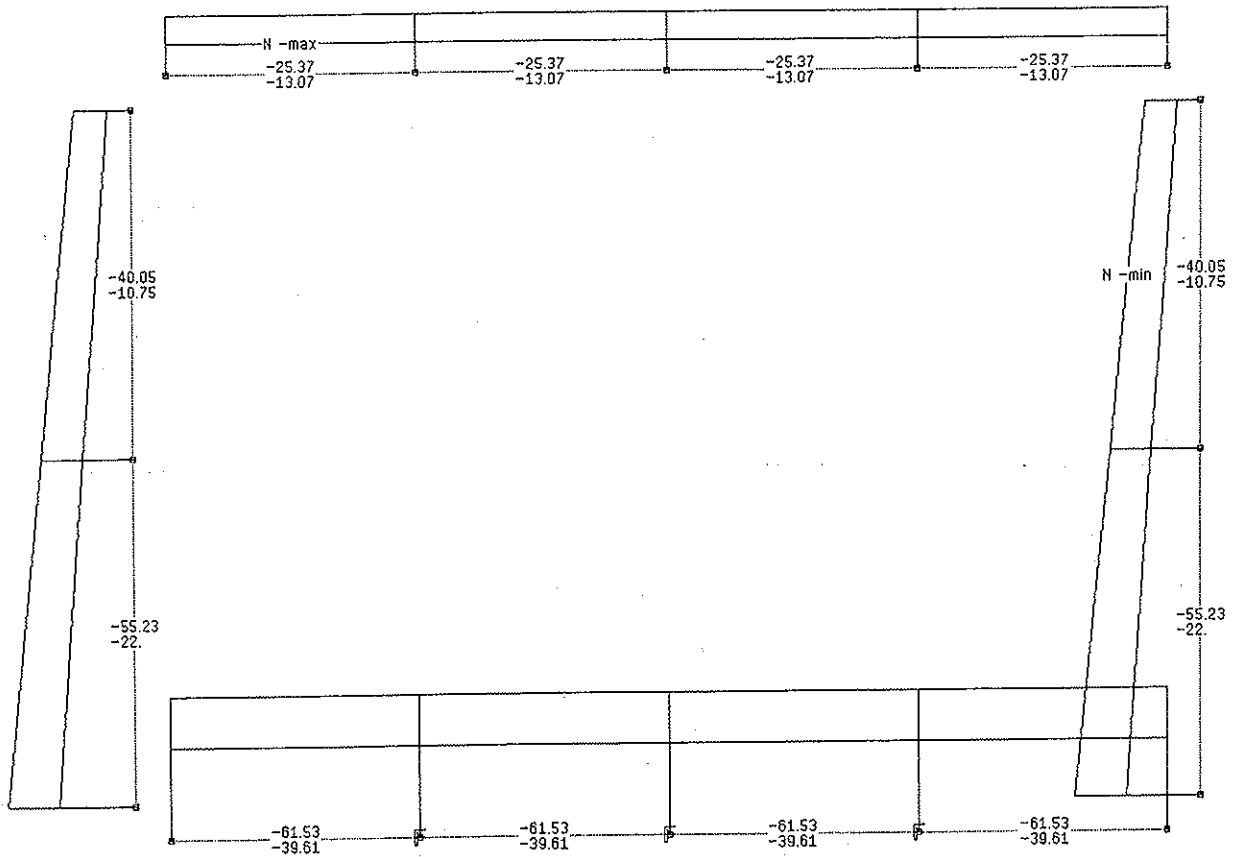

Scale 1 : 32.2

Int. Forces envelope Vz, Design, Subsys. "LIST"

- Structure: Elmnts.
- Envelope Shear force Vz-min, Scale 1.00E-02
min: -5.44E+01 max: 3.43E+01 [kN]
- Envelope Shear force Vz-max, Scale 1.00E-02
min: -3.43E+01 max: 5.44E+01 [kN]
- Text envelopes [kN]

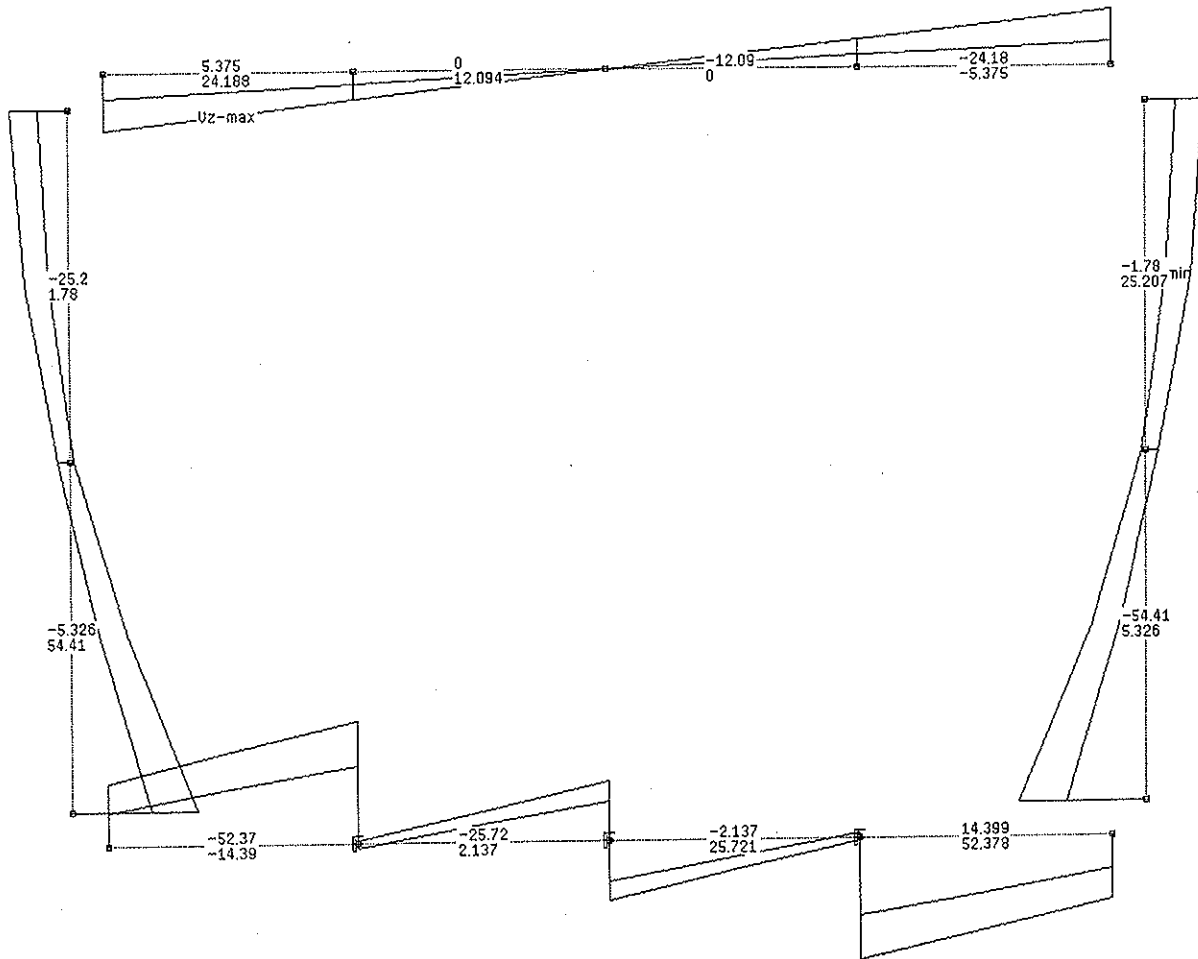

Scale 1 : 34.6

Int. Forces envelope My, Design, Subsys. "LIST"

- Structure: Elmnts.
- Envelope Moment My-min, Scale 1.00E-02
min: -4.38E+01 max: 2.55E+00 [kNm]
- Envelope Moment My-max, Scale 1.00E-02
min: 3.64E-02 max: 4.81E+01 [kNm]
- Text envelopes [kNm]

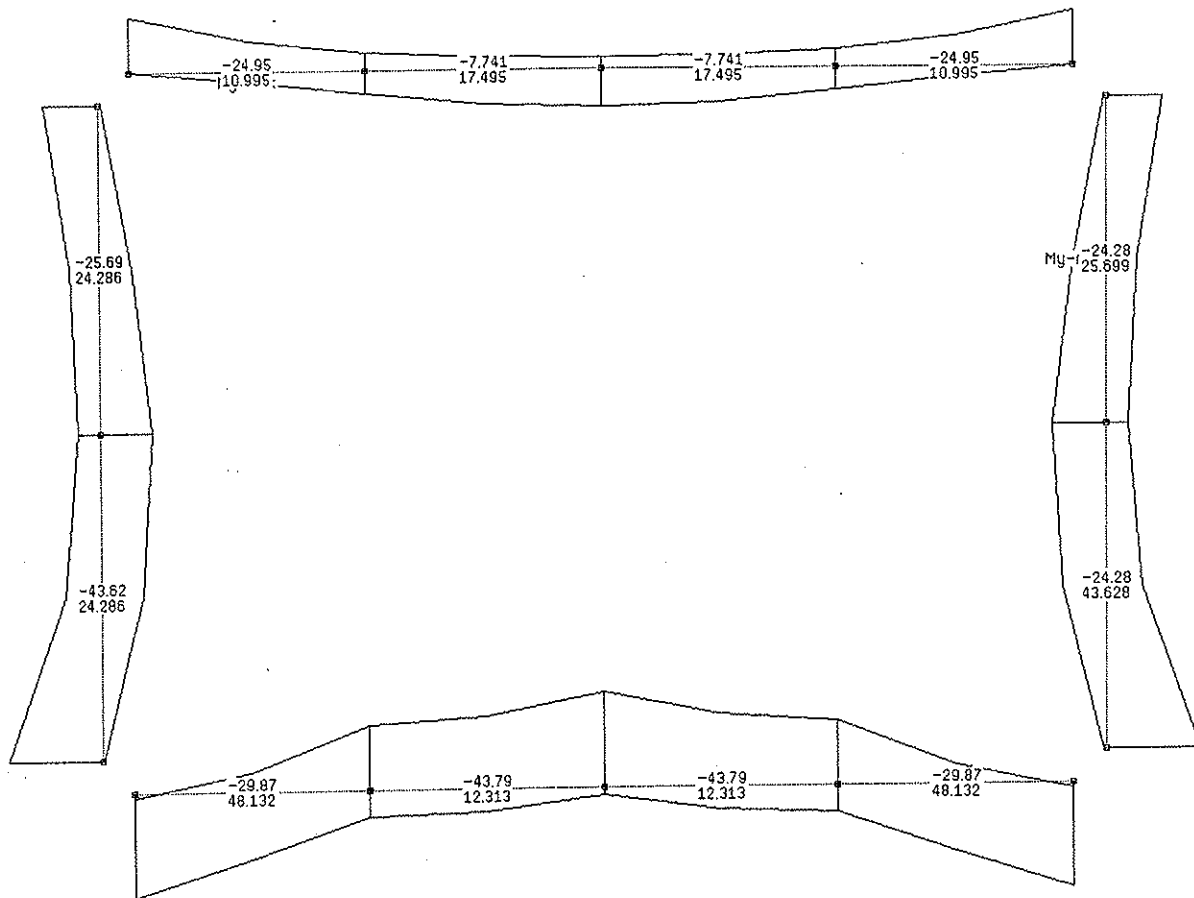

Scale 1 : 34.0

Calcul. As, , Subsys. "LIST"

- Structure: Elmnts.

- Longit.reinf As-upper-tot , Scale 1.00E-01

min: 1.00E+00 max: 3.94E+00 [cm2]

- Longit.reinf As-lower-tot , Scale 1.00E-01

min: 1.00E+00 max: 4.02E+00 [cm2]

- Text As-upper, As-lower, As-stirrups-z(y) [cm2/m]

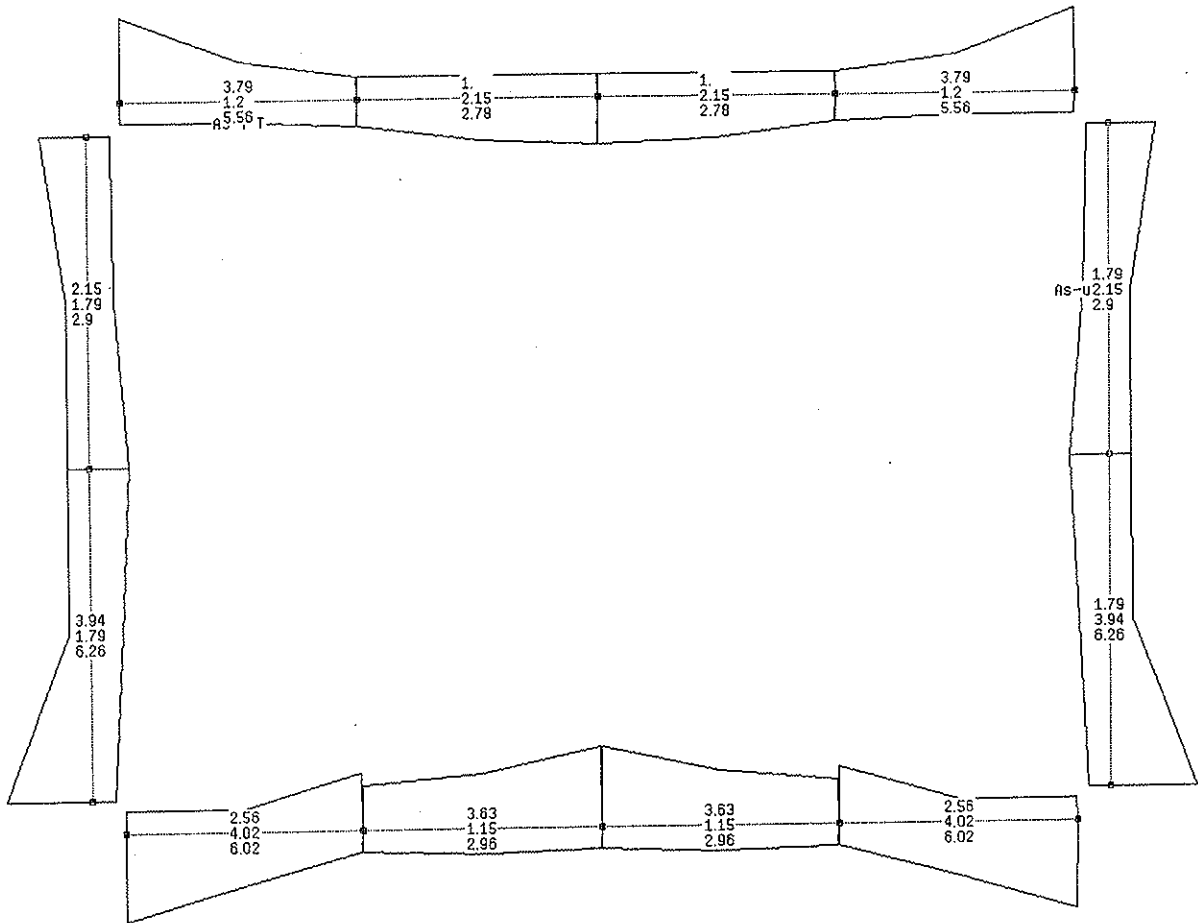

ΣΕΙΣΜΙΚΗ ΕΠΙΛΥΣΗ ΑΝΤΛΙΟΣΤΑΣΙΟΥ

Scale 1 : 30.9

Structure - MODEL

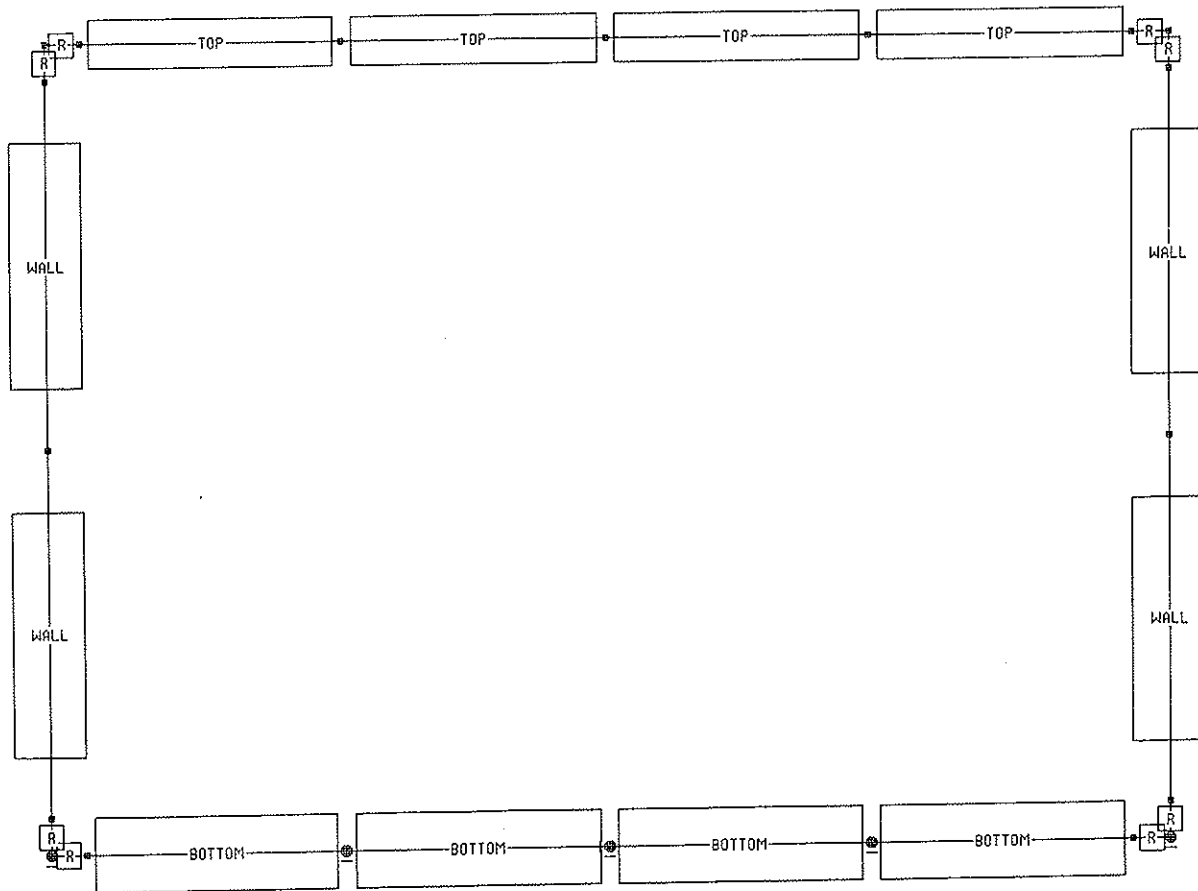

LOAD COMBINATION CG: ''

Loadcase	Factor	Stage	Init.def	Title
20	1.0000			E/Q E/PRESSURES
21	1.0000			E/Q E/PRESSURES+
22	1.0000			E/Q E/PRESSURES-
25	1.0000			INERTIA X
26	1.0000			INERTIA Z

Scale 1 : 75.0
Load case 20

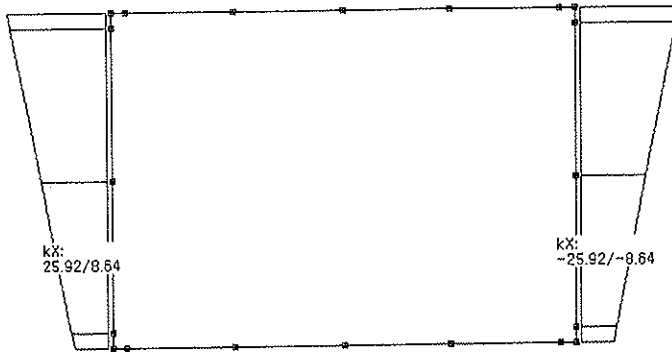

Scale 1 : 75.0
Load case 21

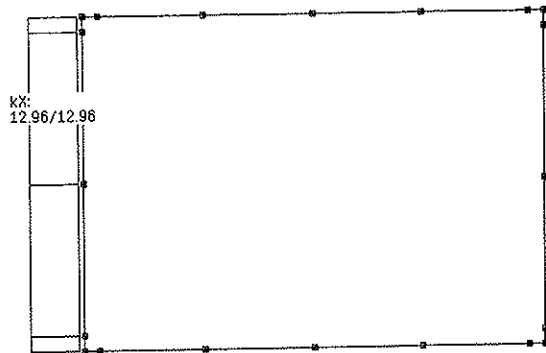

Scale 1 : 75.0
Load case 22

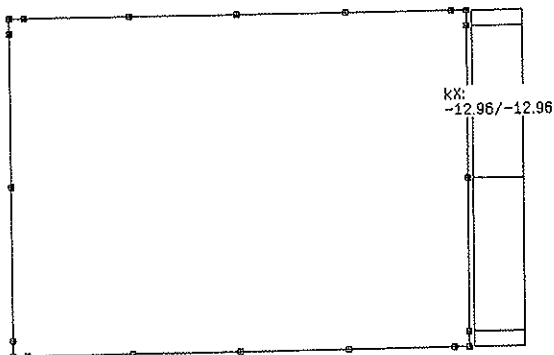

ENVELOPE SPECIFIC.: CH ''

=====

Group	Spec.	Loadcase	Factor	Stage	Title
A	PERM.	1	1.000		SELF WEIGHT
	AND	2	1.000		EARTH PRESSURES
B	PLUS	5	1.000		LIVE LOADS-H/M
C	PLUS	20	1.000		E/Q E/PRESSURES
D	OR	21	1.000		E/Q E/PRESSURES+
	AND	25	1.000		INERTIA X
E	OR	22	1.000		E/Q E/PRESSURES-
	AND	25	-1.000		INERTIA X
F	PLUS	26	0.300000		INERTIA Z
G	OR	26	-0.300000		INERTIA Z

ALTERNATIVE ENVELOPE :

H	PERM.	1	1.000		SELF WEIGHT
	AND	2	1.000		EARTH PRESSURES
I	PLUS	5	1.000		LIVE LOADS-H/M
J	PLUS	26	1.000		INERTIA Z
K	OR	26	-1.000		INERTIA Z
L	PLUS	20	0.300000		E/Q E/PRESSURES
M	OR	21	0.300000		E/Q E/PRESSURES+
	AND	25	0.300000		INERTIA X
N	OR	22	0.300000		E/Q E/PRESSURES-
	AND	25	-0.300000		INERTIA X

=====

Scale 1 : 33.9

Displacements envelope DX [M], GWSP CH, Subsys. "ALL"

- Structure: Elmnts.
- Minimum displacements DX, Scale: 5.0E1
- Text minimum displacements DX [M]
- Maximum displacements DX, Scale: 5.0E1
- Text maximum displacements DX [M]
- Label minimum value DX-Min. [M]
- Label maximum value DX-Max. [M]

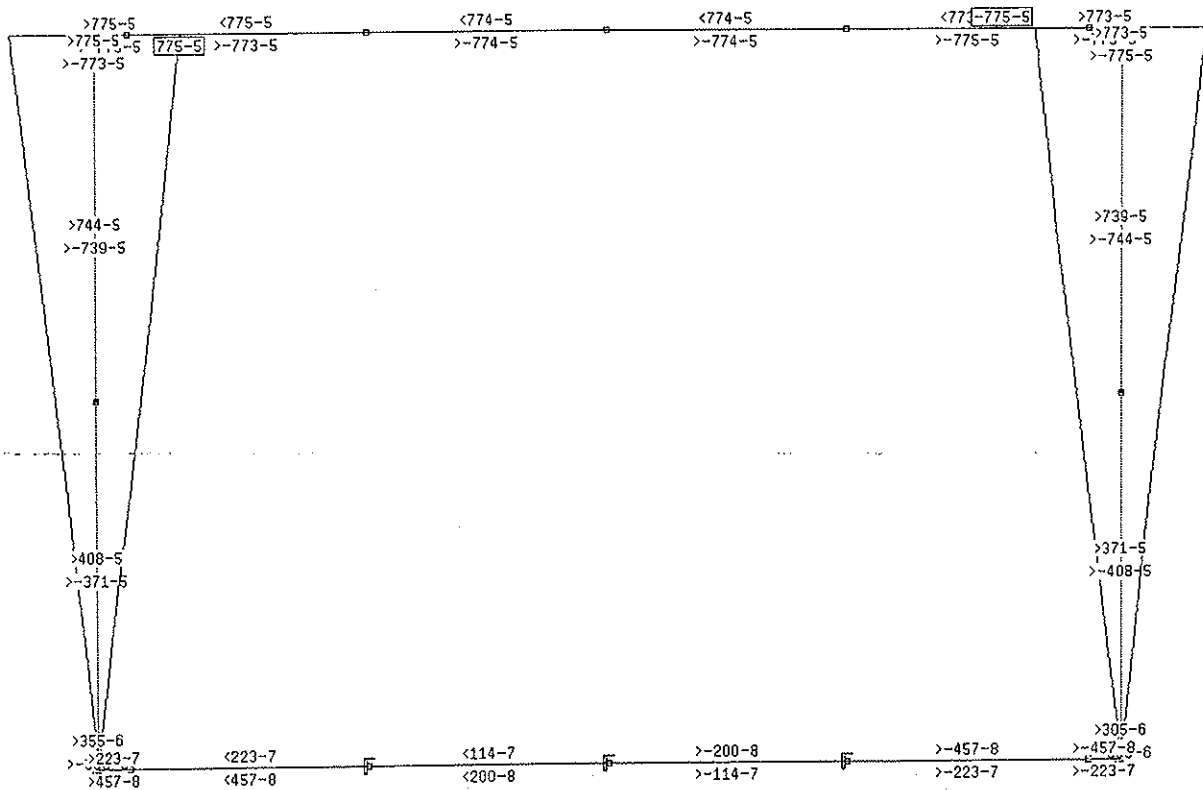

LOAD COMBINATION CI: 'Dead loads'

Loadcase	Factor	Stage	Init.def	Title
1	1.0000			SELF WEIGHT
2	1.0000			EARTH PRESSURES

ENVELOPE SPECIFIC.: CJ 'Variable loads 1 (Design)'

Group	Spec.	Loadcase	Factor	Stage	Title
A		5	1.000		LIVE LOADS-H/M

ENVELOPE SPECIFIC.: CK 'Variable loads 2 (Design)'

Group	Spec.	Loadcase	Factor	Stage	Title
A		20	1.000		E/Q E/PRESSURES
B	OR	21	1.000		E/Q E/PRESSURES+
	AND	25	1.000		INERTIA X
C	OR	22	1.000		E/Q E/PRESSURES-
	AND	25	-1.000		INERTIA X
D	PLUS	26	0.300000		INERTIA Z
E	OR	26	-0.300000		INERTIA Z

ALTERNATIVE ENVELOPE :

F		26	1.000		INERTIA Z
G	OR	26	-1.000		INERTIA Z
H	PLUS	20	0.300000		E/Q E/PRESSURES
I	OR	21	0.300000		E/Q E/PRESSURES+
	AND	25	0.300000		INERTIA X
J	OR	22	0.300000		E/Q E/PRESSURES-
	AND	25	-0.300000		INERTIA X

SPECIFICATINS DESIGN ENVELOPE File:EDSTD, 'Design'

Load group	Char.Actions	Factor	File
1	Dead loads	1.000	(SDESTD)
	Variable loads 1 (Design)	1.000	(GD1STD)
	Variable loads 2 (Design)	1.000	(GD2STD)

Scale 1 : 75.0

Int. Forces envelope N , Design, Subsys. "LIST"

- Structure: Elmnts.
- Envelope Normal force N-min, Scale 5.00E-03
min: -9.48E+01 max: -2.64E+01 [kN]
- Envelope Normal force N-max, Scale 5.00E-03
min: -2.34E+01 max: -2.00E+00 [kN]
- Text envelopes [kN]

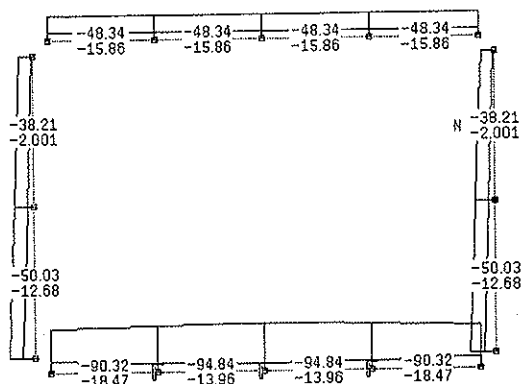

Scale 1 : 75.0

Int. Forces envelope Vz, Design, Subsys. "LIST"

- Structure: Elmnts.
- Envelope Shear force Vz-min, Scale 5.00E-03
min: -7.86E+01 max: 2.07E+01 [kN]
- Envelope Shear force Vz-max, Scale 5.00E-03
min: -2.07E+01 max: 7.86E+01 [kN]
- Text envelopes [kN]

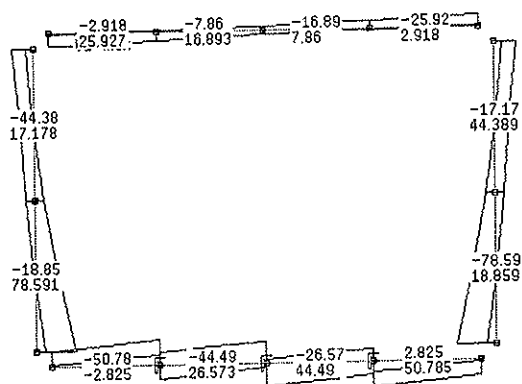

Scale 1 : 75.0

Int. Forces envelope My, Design, Subsys. "LIST"

- Structure: Elmnts.
- Envelope Moment My-min, Scale 1.00E-02
min: -5.66E+01 max: 2.48E+00 [kNm]
- Envelope Moment My-max, Scale 1.00E-02
min: -5.58E+00 max: 6.42E+01 [kNm]
- Text envelopes [kNm]

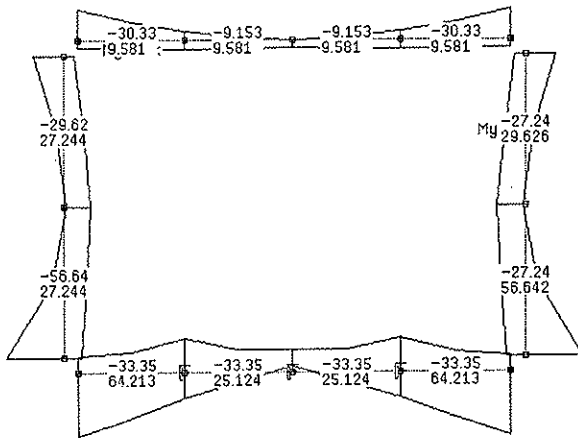

Scale 1 : 75.0

Calcul. As, , Subsys. "LIST"

- Structure: Elmnts.
- Longit.reinf As-upper-tot, Scale 1.00E-01
min: 1.00E+00 max: 5.82E+00 [cm2]
- Longit.reinf As-lower-tot, Scale 1.00E-01
min: 1.00E+00 max: 5.82E+00 [cm2]
- Text As-upper, As-lower, As-stirrups-z(y) [cm2/m]

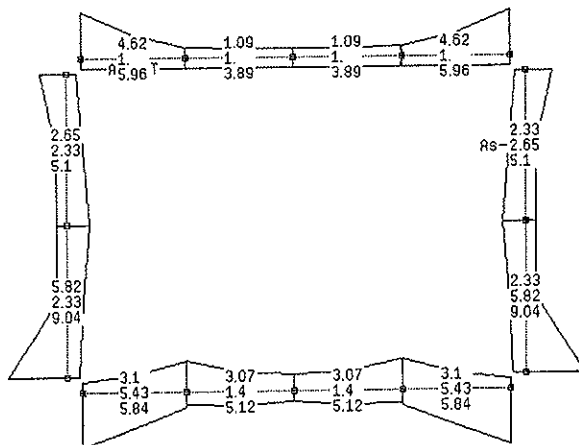

ΣΤΑΤΙΚΗ ΕΠΙΛΥΣΗ ΕΣΩΤ. ΤΟΙΧΕΙΟΥ

Scale 1 : 30.9
Structure - MODEL



LOAD COMBINATION CP: ''

Loadcase	Factor	Stage	Init.def	Title
1	1.0000			SELF WEIGHT
2	1.0000			EARTH PRESSURES
4	1.0000			SHRINKING
5	1.0000			LIVE LOADS-H/M
8	1.0000			WATER PRESSURES OVERFLOW
15	1.0000			TEMPERATURE INCREASE
16	1.0000			TEMPERATURE DECREASE
17	1.0000			TEMPERATURE DIFF. DT1
18	1.0000			TEMPERATURE DIFF. DT2

=====

Scale 1 : 75.0
Load case 1

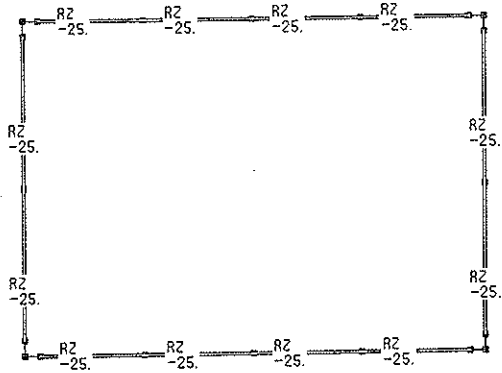

Scale 1 : 75.0
Load case 2

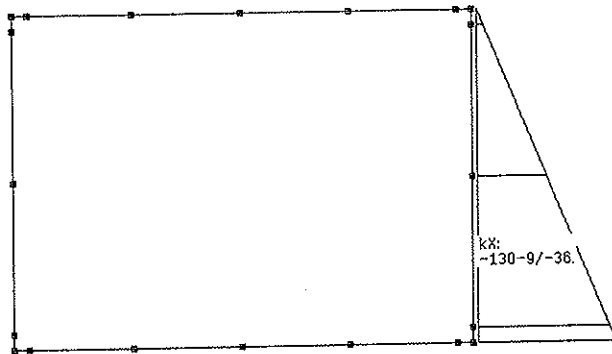

Scale 1 : 75.0
Load case 4

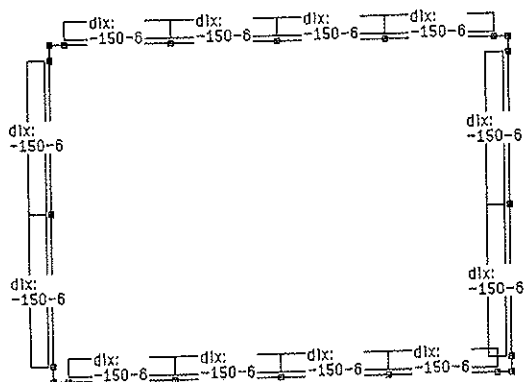

Scale 1 : 75.0
Load case 5

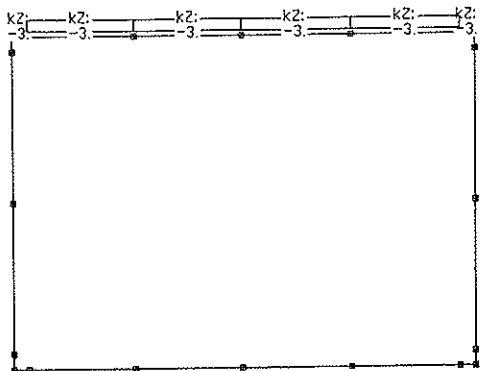

Scale 1 : 75.0
Load case 8

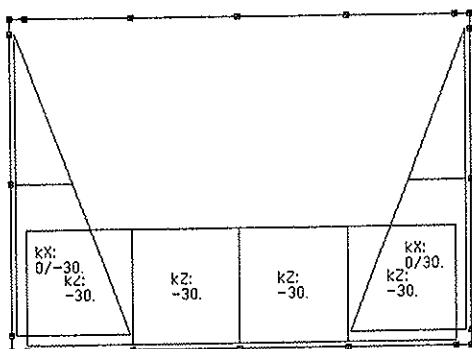

Scale 1 : 75.0
Load case 15

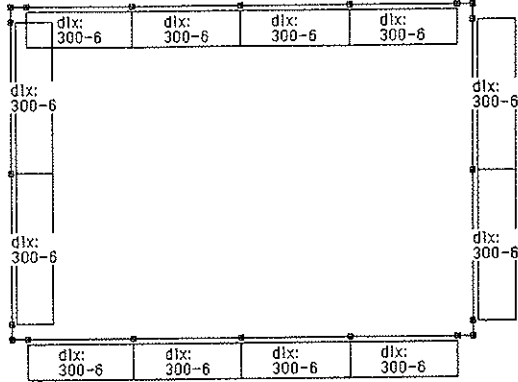

Scale 1 : 75.0
Load case 16

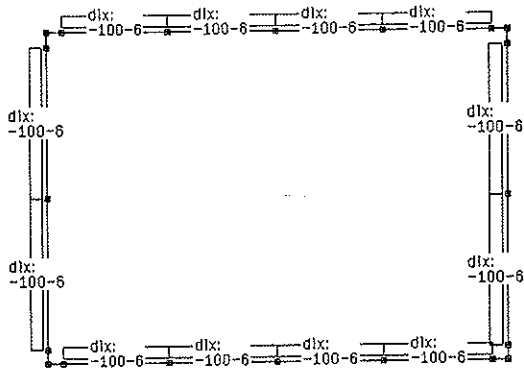

Scale 1 : 75.0
Load case 17

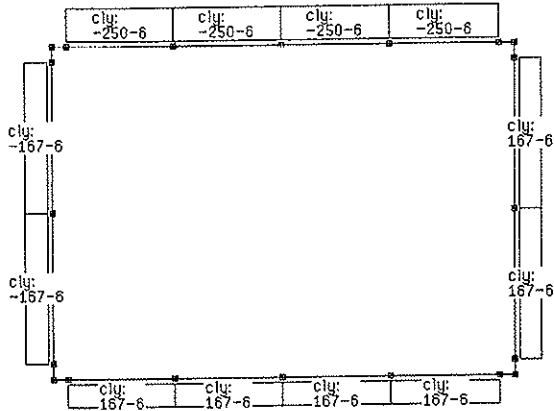

Scale 1 : 75.0
Load case 18

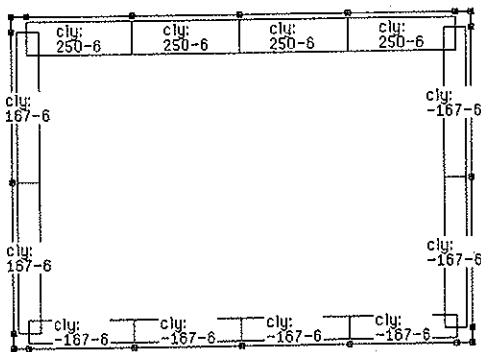

LOAD COMBINATION CM: 'Dead loads'

Loadcase	Factor	Stage	Init.def	Title
1	1.0000			SELF WEIGHT
2	1.0000			EARTH PRESSURES

ENVELOPE SPECIFIC.: CN 'Variable loads 1 (Design)'

Group	Spec.	Loadcase	Factor	Stage	Title
A			5	1.000	LIVE LOADS-H/M
B	PLUS		8	1.000	WATER PRESSURES OVERFLOW

ENVELOPE SPECIFIC.: CO 'Variable loads 3 (Design)'

Group	Spec.	Loadcase	Factor	Stage	Title
A			4	1.000	SHRINKING
B	PLUS		15	1.000	TEMPERATURE INCREASE
C	OR		16	1.000	TEMPERATURE DECREASE
D	PLUS		17	1.000	TEMPERATURE DIFF. DT1
E	OR		18	1.000	TEMPERATURE DIFF. DT2

SPECIFICATINS DESIGN ENVELOPE File:EDSTD, 'Design'

Load group	Char.Actions	Factor	File
1	Dead loads	1.350	(SDESTD)
	Variable loads 1 (Design)	1.500	(GD1STD)
	Variable loads 3 (Design)	1.500	(GD3STD)
OR			
2	Dead loads	1.350	(SDESTD)
	Variable loads 1 (Design)	1.500	(GD1STD)
	Variable loads 3 (Design)	1.500	(GD3STD)
OR			
3	Dead loads	1.000	(SDESTD)
	Variable loads 1 (Design)	1.500	(GD1STD)
	Variable loads 3 (Design)	1.500	(GD3STD)
OR			
4	Dead loads	1.000	(SDESTD)
	Variable loads 1 (Design)	1.500	(GD1STD)
	Variable loads 3 (Design)	1.500	(GD3STD)

Scale 1 : 75.0

Int. Forces envelope N , Design, Subsys. "LIST"

- Structure: Elmnts.
- Envelope Normal force N-min, Scale 5.00E-03
min: -7.42E+01 max: 3.71E+00 [kN]
- Envelope Normal force N-max, Scale 5.00E-03
min: -3.67E+01 max: 6.12E+01 [kN]
- Text envelopes [kN]

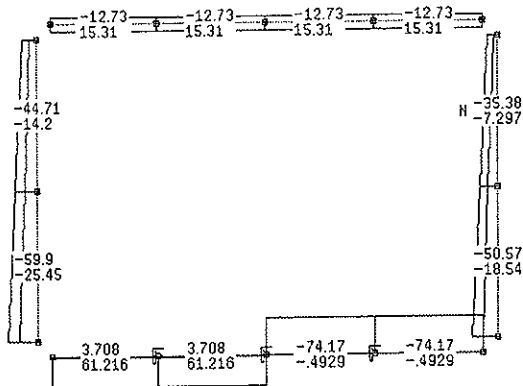

Scale 1 : 75.0

Int. Forces envelope Vz, Design, Subsys. "LIST"

- Structure: Elmnts.
- Envelope Shear force Vz-min, Scale 5.00E-03
min: -6.70E+01 max: 3.47E+01 [kN]
- Envelope Shear force Vz-max, Scale 5.00E-03
min: -2.10E+01 max: 7.70E+01 [kN]
- Text envelopes [kN]

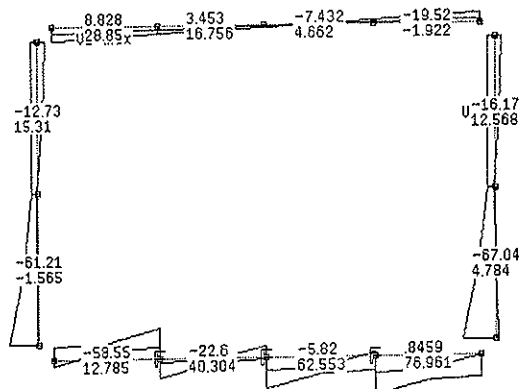

Scale 1 : 75.0

Int. Forces envelope My, Design, Subsys. "LIST"

- Structure: Elmnts.
- Envelope Moment My-min, Scale 5.00E-03
min: -6.92E+01 max: 9.07E+00 [kNm]
- Envelope Moment My-max, Scale 5.00E-03
min: -7.99E+00 max: 7.49E+01 [kNm]
- Text envelopes [kNm]

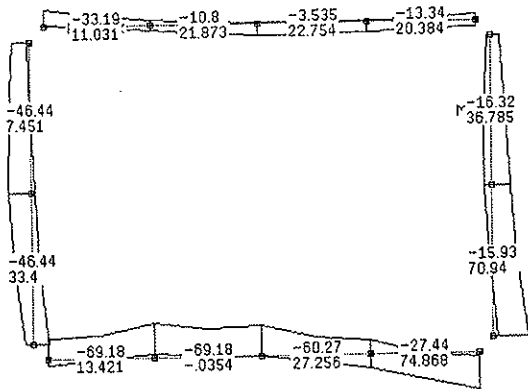

Scale 1 : 75.0

Calcul. As, , Subsys. "LIST"

- Structure: Elmnts.
- Longit.reinf As-upper-tot, Scale 5.00E-02
min: 1.00E+00 max: 8.10E+00 [cm2]
- Longit.reinf As-lower-tot, Scale 5.00E-02
min: 1.00E+00 max: 6.99E+00 [cm2]
- Text As-upper, As-lower, As-stirrups-z(y) [cm2/m]

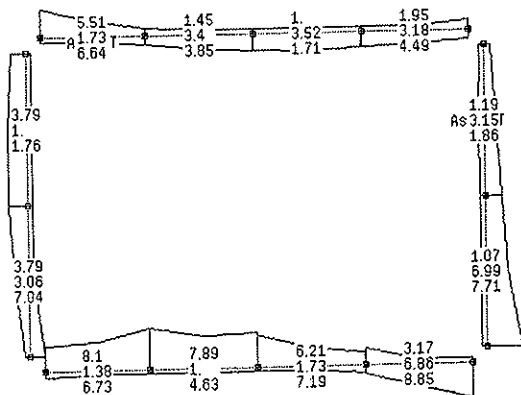

ΣΕΙΣΜΙΚΗ ΕΠΙΛΥΣΗ ΕΣΩΤ. ΤΟΙΧΕΙΟΥ

LOAD COMBINATION CG: ''

Loadcase	Factor	Stage	Init.def	Title
20	1.0000			E/Q E/PRESSURES
22	1.0000			E/Q E/PRESSURES-
23	1.0000			E/Q WATER PRESSURES
24	1.0000			E/Q WATER PRESSURES (R)
25	1.0000			INERTIA X
26	1.0000			INERTIA Z
27	1.0000			E/Q WATER PRESSURES Z

Scale 1 : 75.0
Load case 20

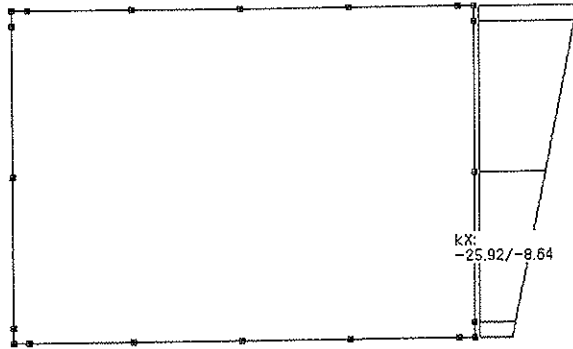

Scale 1 : 75.0
Load case 22

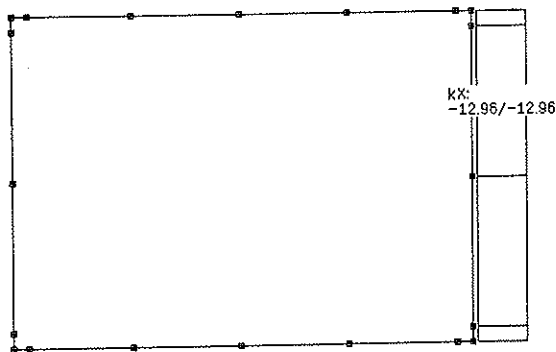

Scale 1 : 75.0
Load case 23

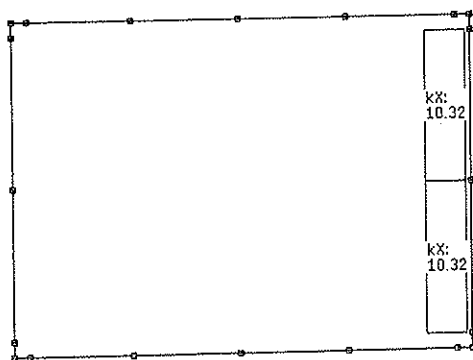

Scale 1 : 75.0
Load case 24

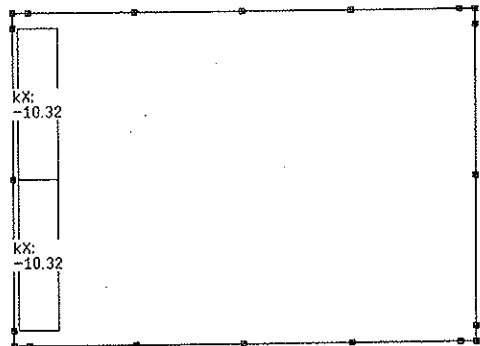

Scale 1 : 75.0
Load case 25

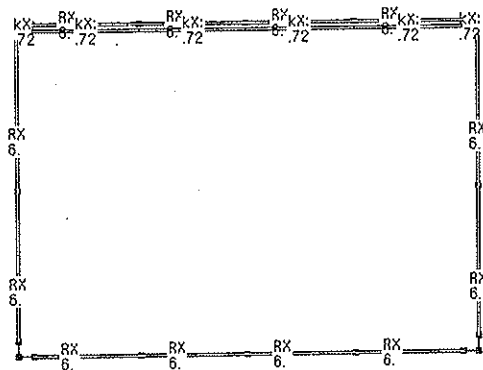

Scale 1 : 75.0
Load case 26

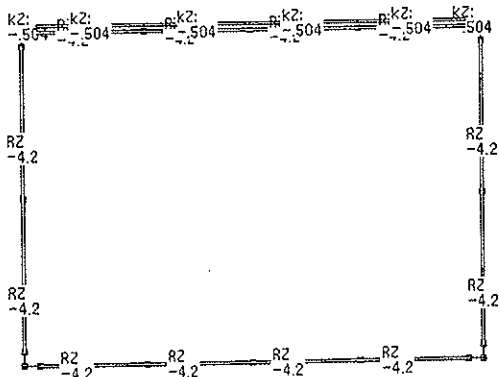

Scale 1 : 75.0
Load case 27

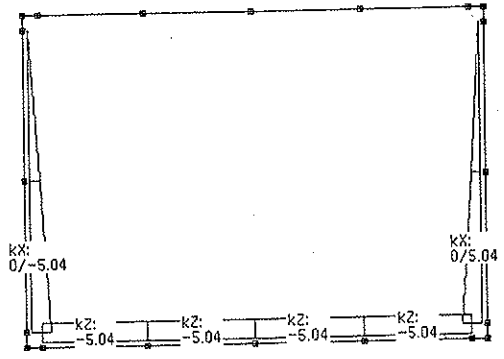

LOAD COMBINATION CH: 'Dead loads'

Loadcase	Factor	Stage	Init.def	Title
1	1.0000			SELF WEIGHT
2	1.0000			EARTH PRESSURES

ENVELOPE SPECIFIC.: CI 'Variable loads 1 (Design)'

Group	Spec.	Loadcase	Factor	Stage	Title
A		5	1.000		LIVE LOADS-H/M
B	PLUS	8	1.000		WATER PRESSURES OVERFLOW

ENVELOPE SPECIFIC.: CJ 'Variable loads 2 (Design)'

Group	Spec.	Loadcase	Factor	Stage	Title
A		20	1.000		E/Q E/PRESSURES
B	OR	23	1.000		E/Q WATER PRESSURES
	AND	25	1.000		INERTIA X
C	OR	22	1.000		E/Q E/PRESSURES-
	AND	24	1.000		E/Q WATER PRESSURES (R)
	AND	25	-1.000		INERTIA X
D	PLUS	26	0.300000		INERTIA Z
	AND	27	0.300000		E/Q WATER PRESSURES Z
E	OR	26	-0.300000		INERTIA Z
	AND	27	-0.300000		E/Q WATER PRESSURES Z

ALTERNATIVE ENVELOPE :

F		26	1.000		INERTIA Z
	AND	27	1.000		E/Q WATER PRESSURES Z
G	OR	26	-1.000		INERTIA Z
	AND	27	-1.000		E/Q WATER PRESSURES Z
H	PLUS	20	0.300000		E/Q E/PRESSURES
I	OR	23	0.300000		E/Q WATER PRESSURES
	AND	25	0.300000		INERTIA X
J	OR	22	0.300000		E/Q E/PRESSURES-
	AND	24	0.300000		E/Q WATER PRESSURES (R)
	AND	25	-0.300000		INERTIA X

SPECIFICATINS DESIGN ENVELOPE File:EDSTD, 'Design'

Load group	Char.Actions	Factor	File
1	Dead loads	1.000	(SDESTD)
	Variable loads 1 (Design)	1.000	(GD1STD)
	Variable loads 2 (Design)	1.000	(GD2STD)

Scale 1 : 75.0

Int. Forces envelope N , Design, Subsys. "LIST"

- Structure: Elmnts.
- Envelope Normal force N-min, Scale 5.00E-03
min: -1.08E+02 max: -1.17E+01 [kN]
- Envelope Normal force N-max, Scale 5.00E-03
min: -2.80E+01 max: 8.87E+01 [kN]
- Text envelopes [kN]

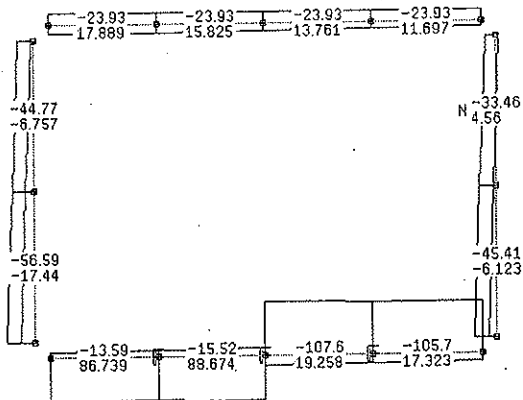

Scale 1 : 75.0

Int. Forces envelope Vz, Design, Subsys. "LIST"

- Structure: Elmnts.
- Envelope Shear force Vz-min, Scale 5.00E-03
min: -9.66E+01 max: 2.28E+01 [kN]
- Envelope Shear force Vz-max, Scale 5.00E-03
min: -2.01E+00 max: 8.10E+01 [kN]
- Text envelopes [kN]

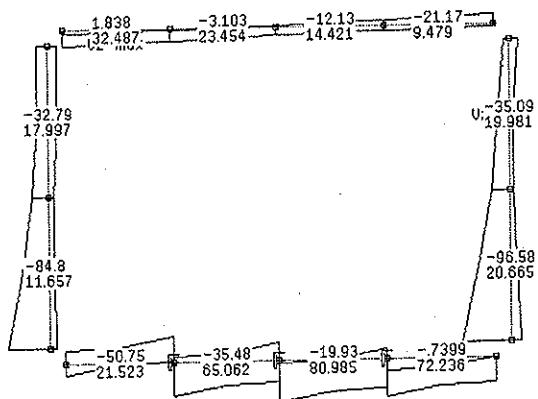

Scale 1 : 75.0

Int. Forces envelope My, Design, Subsys. "LIST"

- Structure: Elmnts.
- Envelope Moment My-min, Scale 5.00E-03
min: -7.56E+01 max: 2.54E+00 [kNm]
- Envelope Moment My-max, Scale 5.00E-03
min: -1.05E+01 max: 9.85E+01 [kNm]
- Text envelopes [kNm]

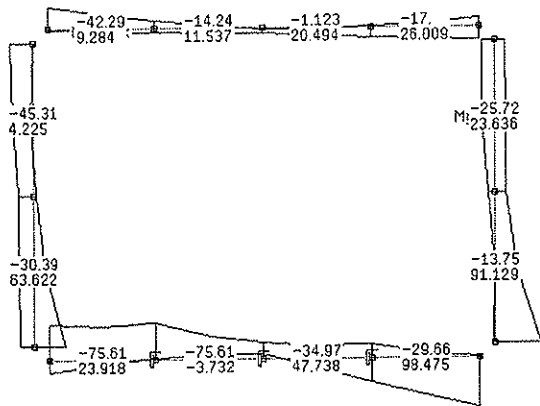

Scale 1 : 75.0

Calcul. As, , Subsys. "LIST"

- Structure: Elmnts.
- Longit.reinf As-upper-tot, Scale 5.00E-02
min: 1.00E+00 max: 9.17E+00 [cm2]
- Longit.reinf As-lower-tot, Scale 5.00E-02
min: 1.00E+00 max: 9.79E+00 [cm2]
- Text As-upper, As-lower, As-stirrups-z(y) [cm2/m]

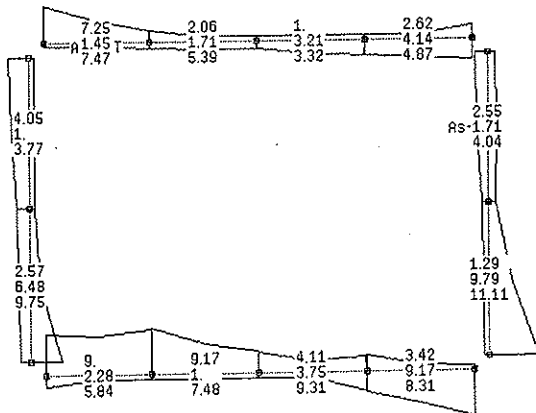

ΚΤΙΡΙΟ Ι
ΥΠΟΛΟΓΙΣΜΟΣ ΔΑΠΕΔΟΥ ΜΗΧΑΝΟΣΤΑΣΙΟΥ

φορέας

Κλιμ. 1 :69.6

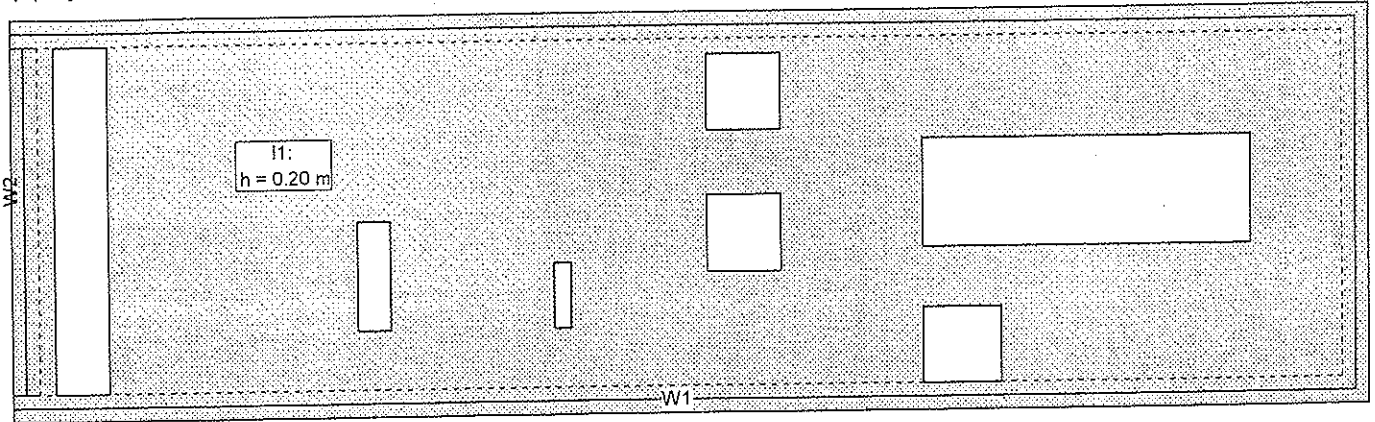

Fe-Netz

Κλιμ. 1 :69.6

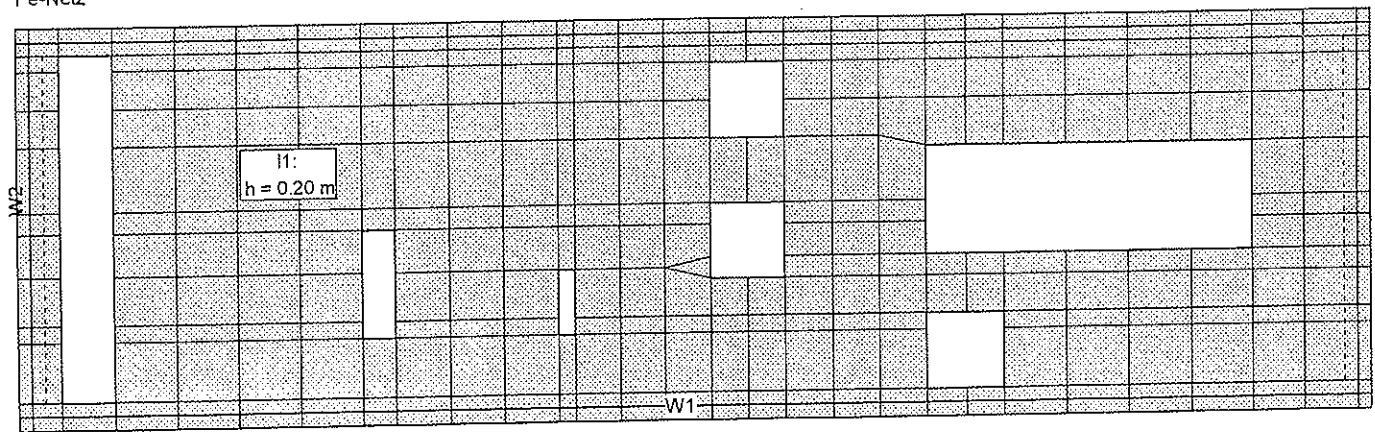

ΔΕΔΟΜΕΝΑ ΚΑΤΑΣΚΕΥΗΣ

ΠΑΧΗ ΚΑΙ ΥΛΙΚΟ

ισότροπη	μέτρο E [kN/m ²]	ν	πάχος [m]	άνω στάθμη [m]
I1	2.9E+7	0.17	0.20	0

ΤΟΙΧΩΜΑΤΑ

Id	μόνον θλίψη	τύπος	sdz [kN/m ²]	srx [kN]	sry [kN]	πλάτος [m]	ύψος [m]	μέτρο E [kN/m ²]
W1		γενικά	δεσμευμένη	(1.007E+5)	1.E+7	0.25	1.50	2.9E+7
W2		ελεύθερα στρεπτή	δεσμευμένη	ελεύθερη	ελεύθερη	0.25	1.50	2.9E+7

ΛΙΣΤΑ ΦΟΡΤΙΣΕΩΝ

α.α. φόρτισης	Τύπος	Δράση	Όνομα
1	Φορτία	-	SELF WEIGHT
2	Φορτία	-	DEAD LOADS
3	Φορτία	-	LIVE LOADS

Φόρτιση 1: SELF WEIGHT

Κλιμ. 1 :69.6

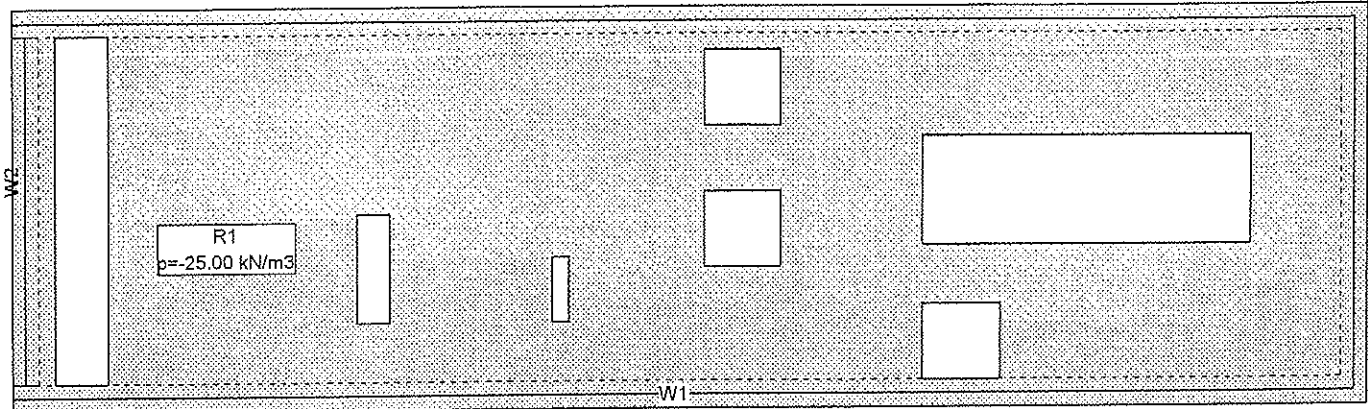

Φόρτιση 2: DEAD LOADS

Κλιμ. 1 :69.6

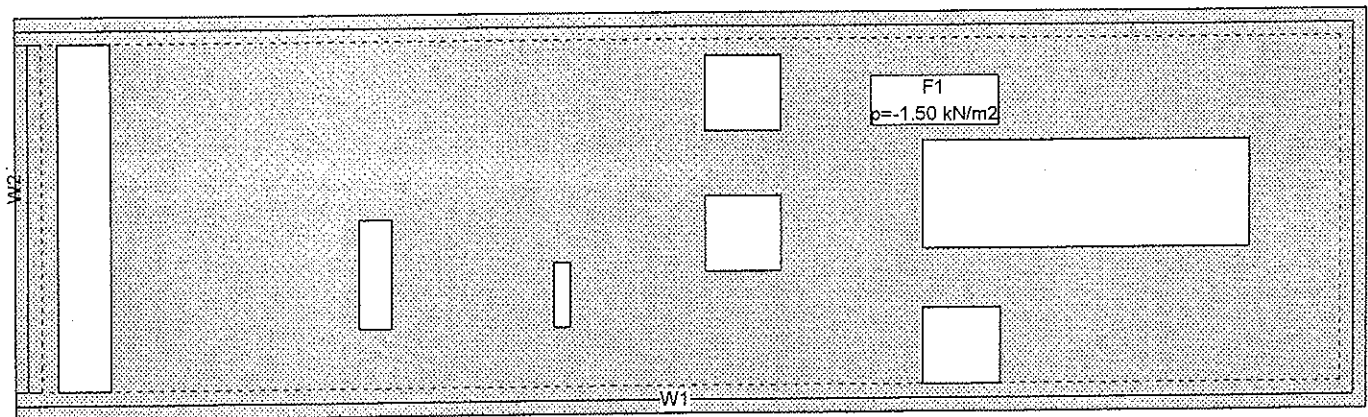

Φόρτιση 3: LIVE LOADS

Κλιμ. 1 :69.6

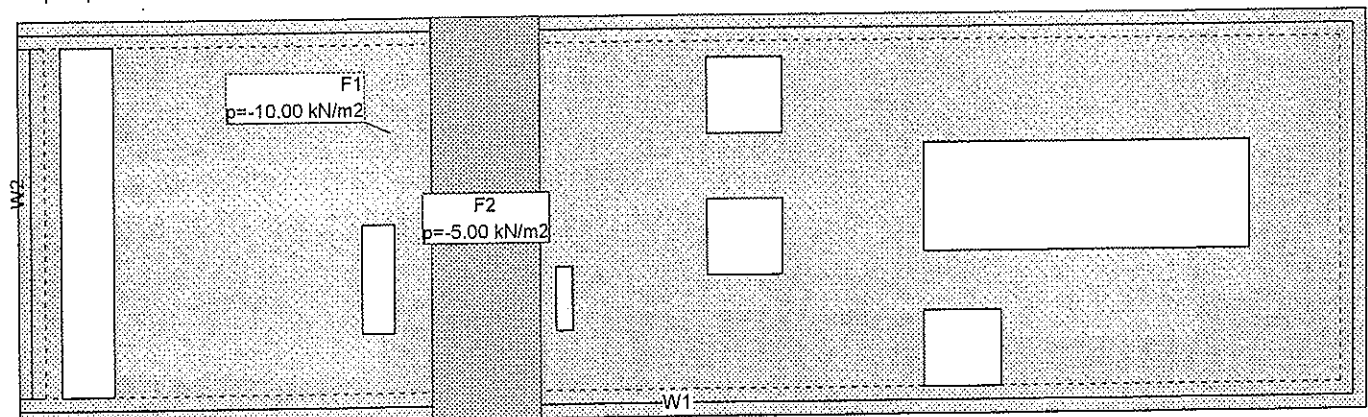

Περιβάλλουσες βέλους κάμψης: Minima: OPL1, βήμα ισουψών: 0.05 mm, γραμμή αναφοράς: 0.00 mm

Κλίμ. 1 :70.8

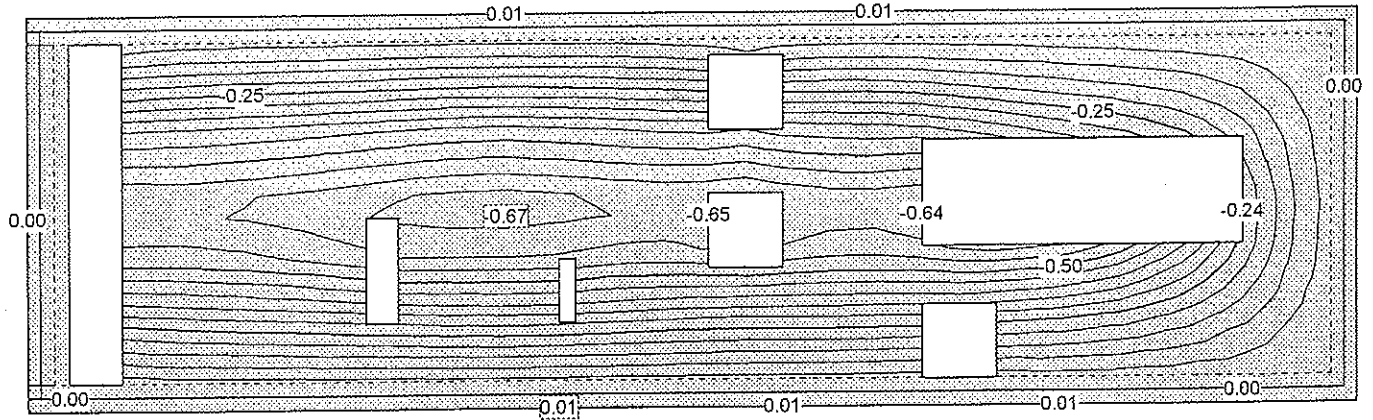

Περιβάλλουσες για το βέλος κάμψης: Minima, Προδιαγραφή σχηματισμού περιβαλλουσών: OPL1, συντελεστής μεγέθυνσης: 2000.0

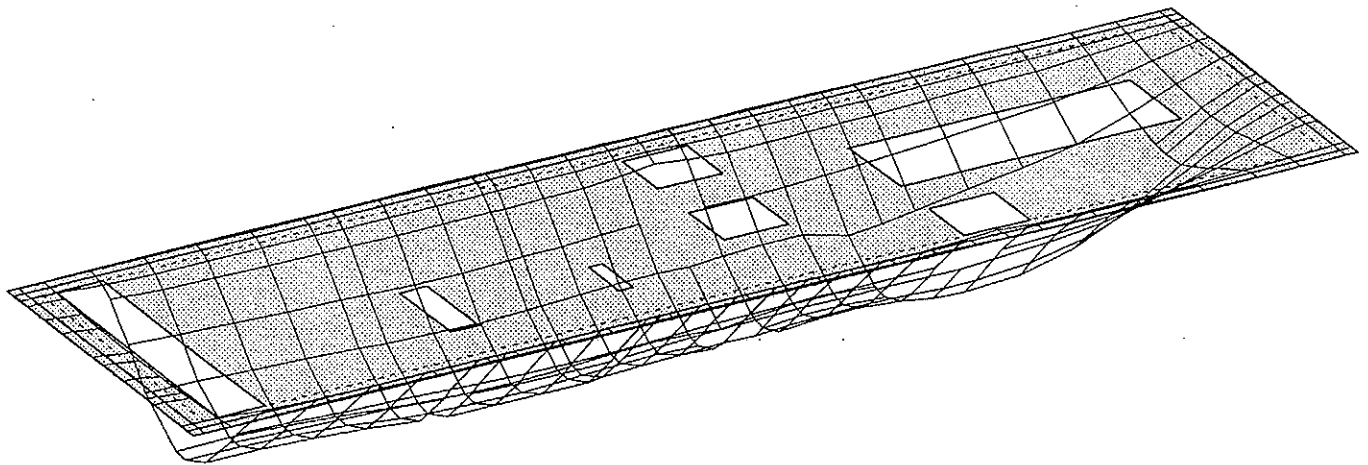

ΠΡΟΔΙΑΓΡΑΦΗ ΠΕΡΙΒΑΛΛΟΥΣΩΝ Κανονισμός: GR-Norm 95 (Επαλληλία κατά EC2)

ΔΡΑΣΗ: OPL11
 μόνιμα L1: [1.35] SELF WEIGHT
 L2: [1.35] DEAD LOADS
 πλέον όπου είναι καθοριστικῶ3: [1.50] LIVE LOADS

ΠΡΟΔΙΑΓΡΑΦΗ ΠΕΡΙΒΑΛΛΟΥΣΩΝ: OPL1

τύπος ελέγχου: ασφάλεια έναντι αστοχίας
 δράσεις καταστάσεις επικινδυνότητας

Nr	Name	1
1	OPL11	1

διατομές οπλισμού ax1:

βήμα ισουψών: 0.100 cm2/m, γραμμή αναφοράς: 0.000 cm2/m
 Προδιαγραφή: OPL1, C20/25, S500, γc=1.50, γs=1.15

Κλιμ. 1:90.0

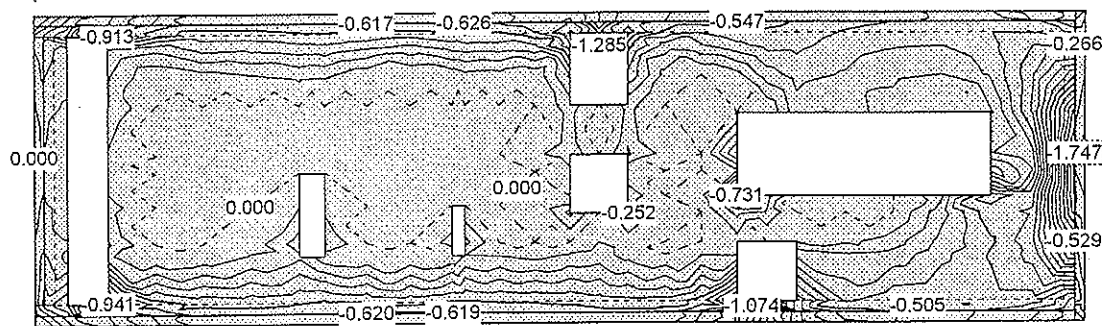

διατομές οπλισμού ay1:

βήμα ισουψών: 0.200 cm2/m, γραμμή αναφοράς: 0.000 cm2/m
 Προδιαγραφή: OPL1, C20/25, S500, γc=1.50, γs=1.15

Κλιμ. 1:90.0

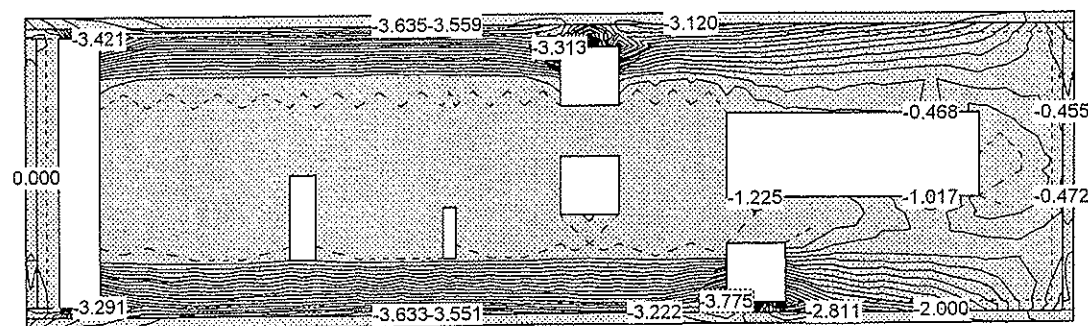

διατομές οπλισμού axb:

βήμα ισουψών: 0.100 cm2/m, γραμμή αναφοράς: 0.000 cm2/m
 Προδιαγραφή: OPL1, C20/25, S500, γc=1.50, γs=1.15

Κλιμ. 1:90.0

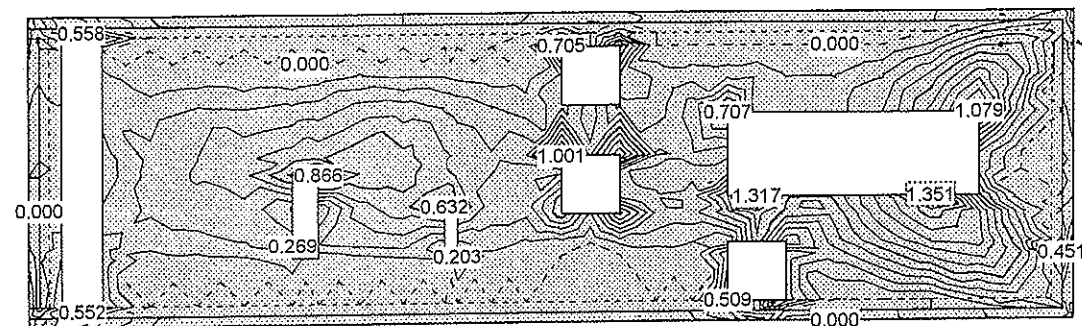

διατομές οπλισμού ayb:

βήμα ισουψών: 0.200 cm2/m, γραμμή αναφοράς: 0.000 cm2/m
 Προδιαγραφή: OPL1, C20/25, S500, γc=1.50, γs=1.15

Κλιμ. 1:90.0

